



**Trex**<sup>®</sup>

CREATE OUTDOOR SPACES You Never Thought Possible

**Trex**<sup>®</sup> RainEscape<sup>®</sup>

DECK DRAINAGE SYSTEM

# Expand your outdoor living space with TREX® RainEscape® Deck Drainage System

protects the space below your deck from rain, sun and other elements.

water flows through system and on to the ground or into a water storage system.

accessorize by adding:  
• ceiling fans • stereo speakers  
• recessed lighting • tv screens  
• furniture.



Copyright 2016 - Trex Company, Inc.



Add Lighting Fixtures



Create Underdeck Storage



Enjoy Entertainment Systems



Install Ceiling Fans

## MAXIMIZE YOUR OUTDOOR LIVING ENVIRONMENT NOW

With your Trex RainEscape system and ceiling/soffit in place, you are ready to maximize your outdoor living environment with features such as lighting fixtures, ceiling fans, speakers, quality outdoor furniture; an outdoor fire pit. Your only limit is your imagination!

# Trex® RainEscape®

DECK DRAINAGE SYSTEM

## Installation Guide

In your hands, you're holding everything you need to build your Trex® RainEscape® deck drainage system. This step-by-step guide will show you how to turn your underdeck into an outdoor living space.



## TREX® RAINESCAPE® INSTALLATION GUIDE

## CONTENTS

**BASIC INSTALLATION**

Parts .....	3
Tools .....	3
Prep .....	3
Installing the Trex RainEscape Downspout .....	3
Installing the Trex RainEscape Trough .....	4
Tape All Seams .....	5
Installing a Gutter System .....	5

**MODIFICATIONS & SPECIAL CASES**

Single Picture Frame .....	6
Double or Triple Picture Frame .....	6
Cantilevered Downspout .....	7
Obstructions & Posts .....	7
Cutting Around Downspouts and Obstructions .....	7
Double Extended Decks .....	8
Low Profile Can Lights .....	8
Modified Downspouts .....	8
Installing a Trough Over a Double or Triple Beam .....	8

<b>INSTALLATION OVER A TREX ELEVATIONS™ SYSTEM</b> .....	9
--	---

<b>WARRANTY</b> .....	10
-----------------------	----

<b>Q &amp; A</b> .....	12
------------------------	----

# BASIC INSTALLATION

## PARTS

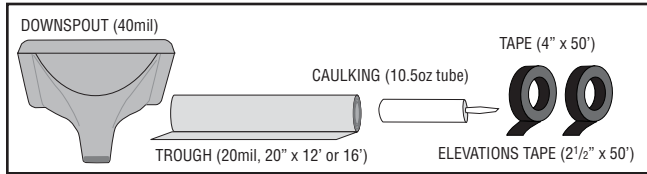

## TOOLS



## 1. PREP

Read all instructions completely before beginning.

Place a midspan nailer on the underside of joist to keep them straight and prevent rolling.

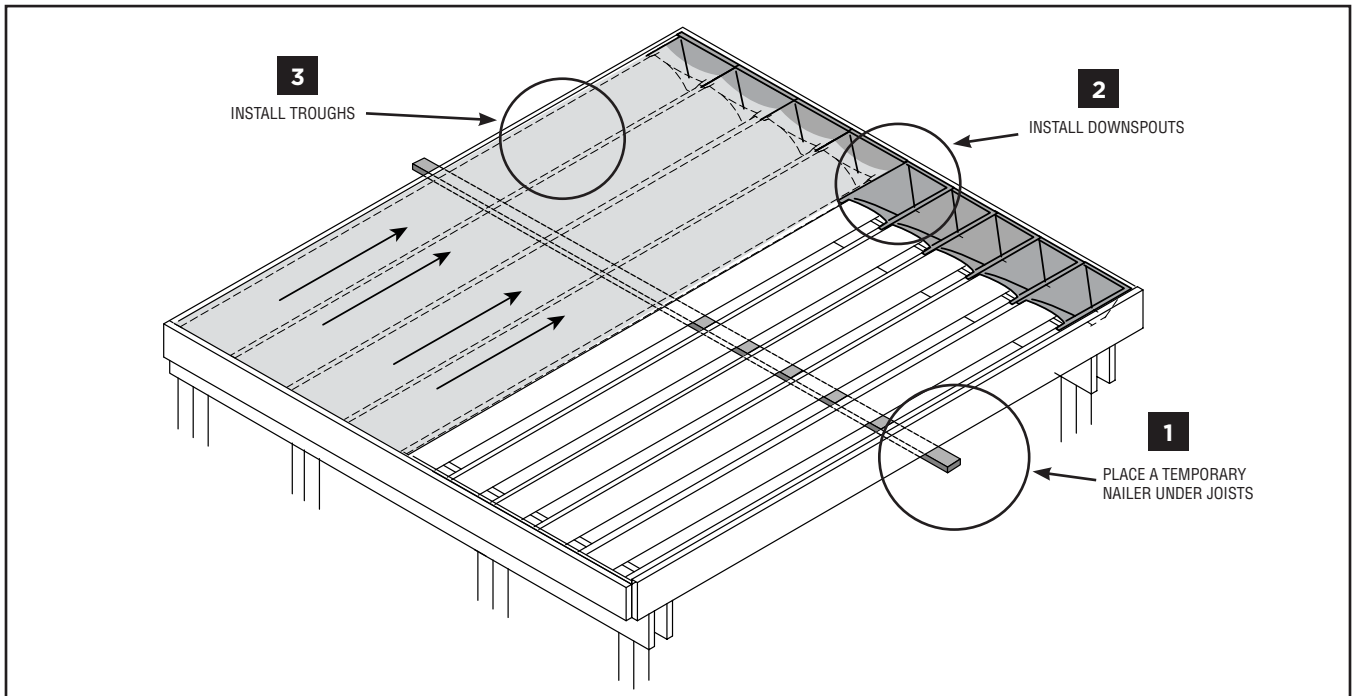
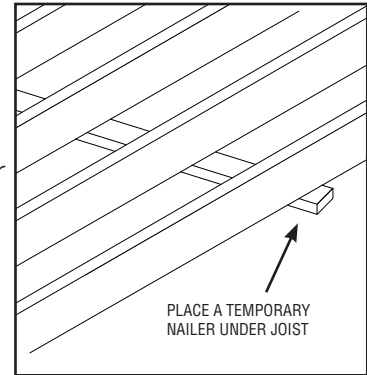

## 2. INSTALLING THE TREX® RAINESCAPE® DOWNSPOUT

- » Cut downspouts along one 12" or 16" side on score mark based on joist spacing.
- » Install all downspouts along rim joists and/or ledger board. Cut-out side should face open deck bay.

» Downspout should extend 1" into gutter: cut or extend as necessary.

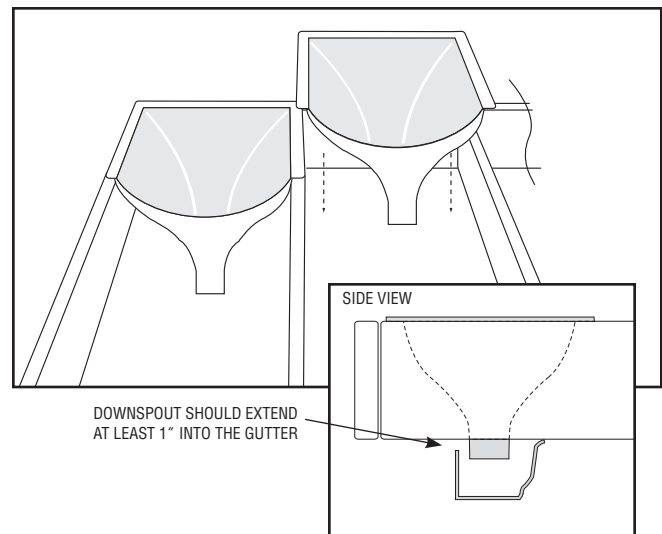
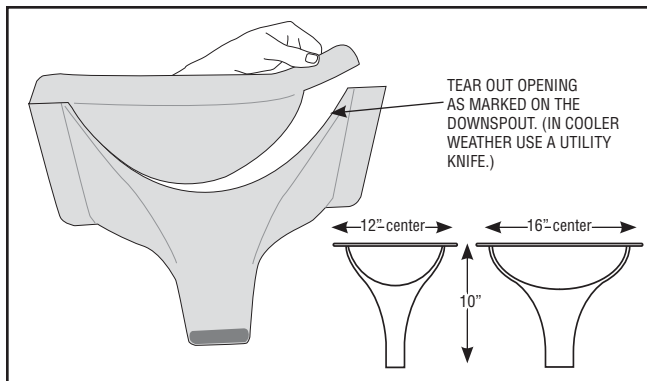

## BASIC INSTALLATION (CONT.)

### 3. INSTALLING THE TREX® RAINEscape® TROUGH

- » For ease of installation, it is recommended that you fold a heavy crease down the center of the trough.
- Be sure to account for the offset if installing for a 12" joist bay. (3A)

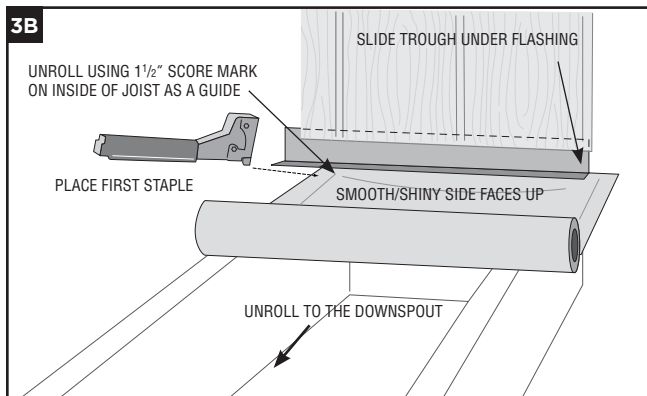
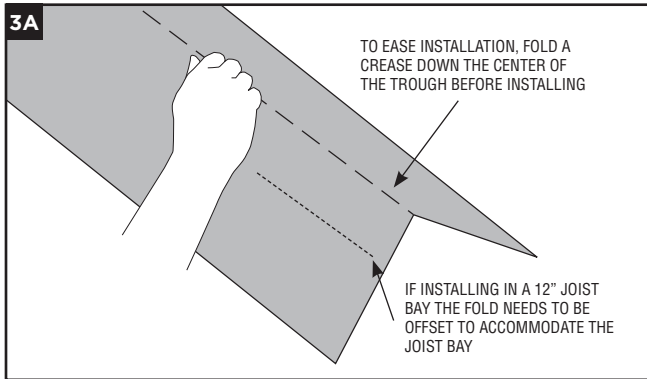

- » When working with the Trex RainEscape trough material, ensure that the smooth/shiny side always faces up. (3B)
- » Line up the 1 1/2" score with the second joist. (3B)
- » If there is no flashing at the ledger, slide 3" of trough material under the existing siding. (3C)

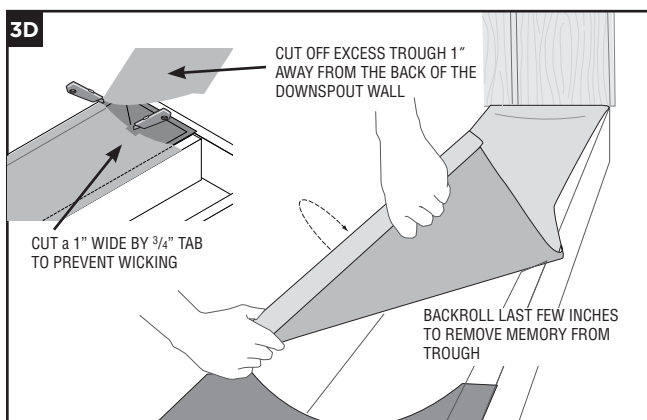
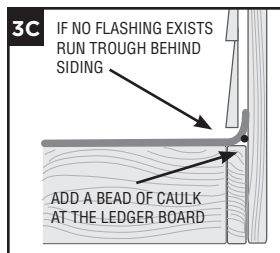

- » Place first staple at ledger board on 1 1/2" score mark inside joist to tack trough, on second joist. (3B)
- » Unroll trough to downspout using 1 1/2" score mark on inside joist as guide. (3E)
- » Cut trough to length to back wall of downspout.
- » To remove memory from sheet, backroll the last few inches of the trough. (3D)
- » Pull trough tight to ensure memory is released, and place second staple on inside joist through downspout. (3D)
- » On outside joist, form a trough into downspout while lining up the edge of the score mark with inside of joist. Place third staple through trough and downspout on outside joist.
- » Cut a 1" wide by 3/4" tab at center edge of trough (fold tab down) to prevent wicking. (3D)

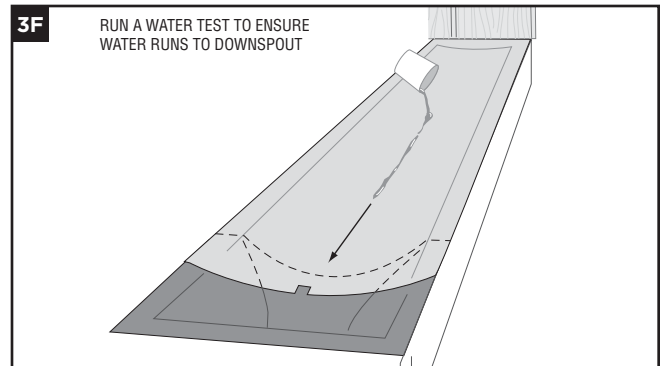
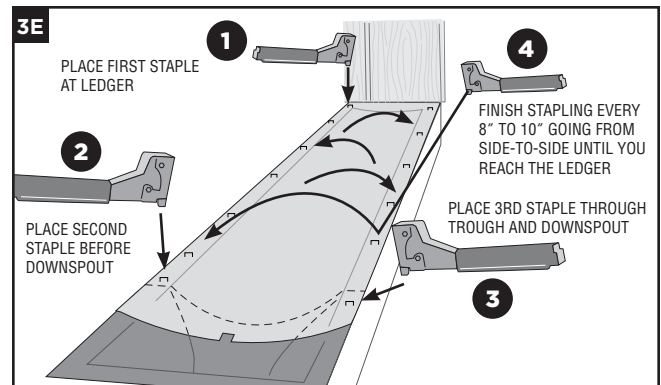

- » Pull corner at ledger and outside joist tight keeping entire length of trough smooth and wrinkle-free so as not to impede water flow. (3E)
- » Place fourth staple on outside joist at ledger. (3E)
- » Continue stapling every 6" to 8" from downspout to ledger on both joists to secure. (3E)
- » To test for correct slope, pour cup of water on trough at ledger board ensuring water runs to downspout. (3F)
- » Follow above step for remaining troughs.

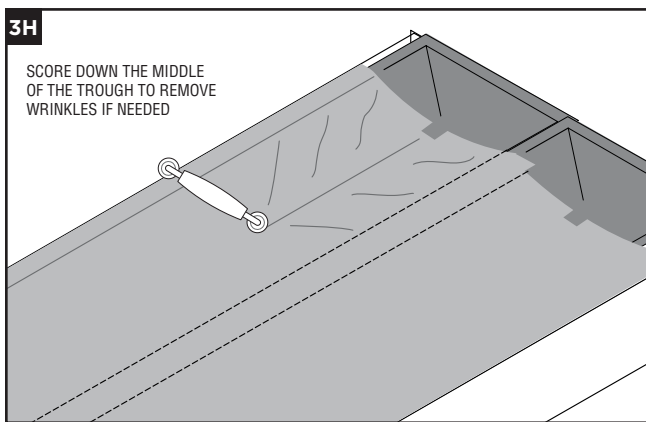
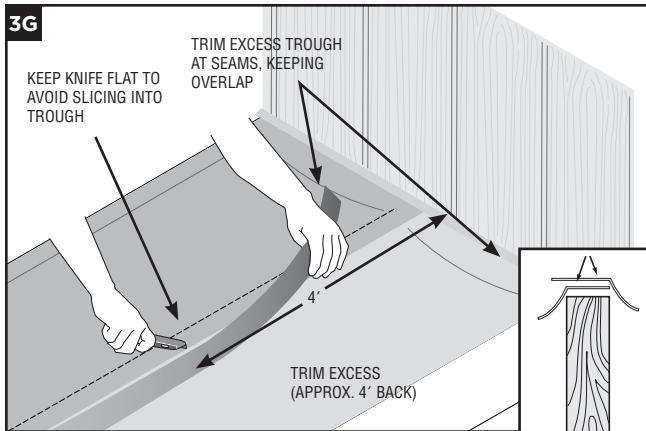

**TAPE ALL SEAMS**

- » Trim excess trough at seams, keeping overlap so tape will cover the top of the joist and seams (3G)
- » Using Trex® RainEscape® tape, tape ALL seams, joints and perimeter making sure the flashing is taped to the trough. (3H)

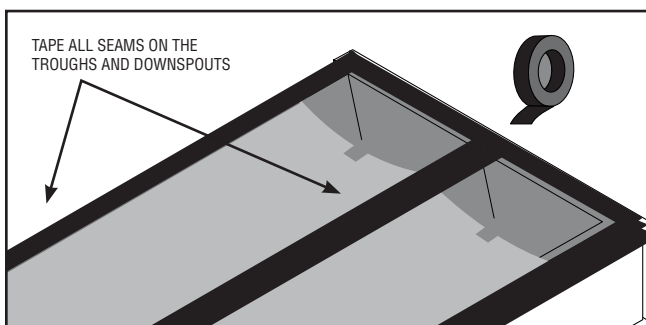

NOTE: Trex RainEscape Caulk can be used instead of tape, if preferred. If using caulk, caulk must be applied between ALL product overlaps and between product and joist on perimeter of deck. In cases where tape will not stick, (usually on brick or stucco)

**INSTALLING A GUTTER SYSTEM (not included)**

- » Before installing a gutter system perform a water test to clean out the system and check for any leaks
- » Attach a standard gutter system to collect the water from the Trex RainEscape downspouts.

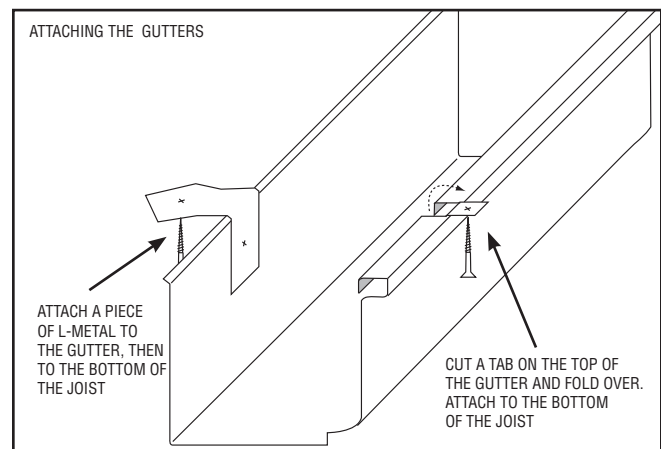
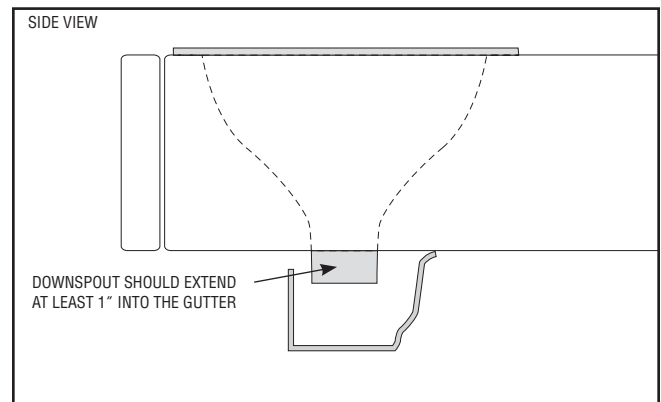
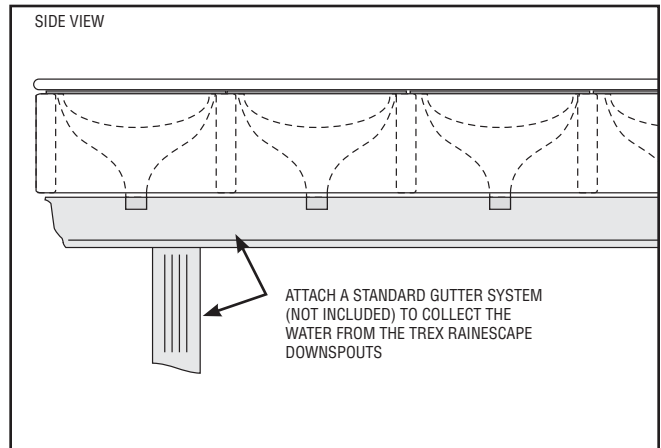

# MODIFICATIONS AND SPECIAL CASES

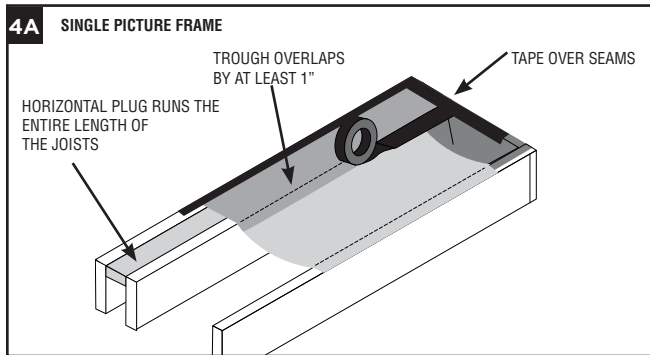
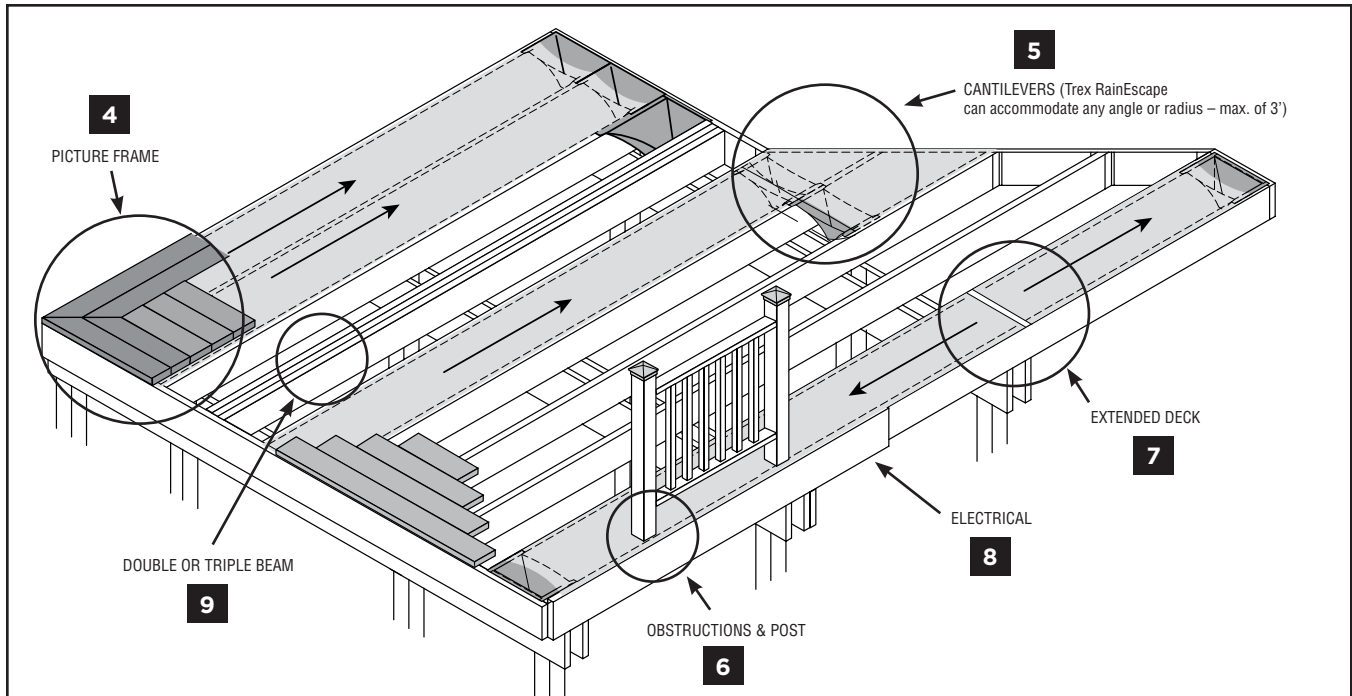

## 4A. SINGLE PICTURE FRAME

- » Place a horizontal nailer flush with the top of the joist from the ledger board to the rim joist.
- » Cover nailer with trough, making sure to overlap adjoining downspout and trough.
- » Cover all seams with tape.

## 4B. DOUBLE OR TRIPLE PICTURE FRAME: 2 X 4 SHIMS

- » Install the Trex® RainEscape® system as per previous instructions. (Page 3-5)
- » Tape all joints and seams.
- » Place 2 x 4 pressure treated shim blocking on top of the installed downspouts and troughs.
- » Attach decking. (When attaching decking use fasteners that do not penetrate all the way through the 2 x 4 shim.)

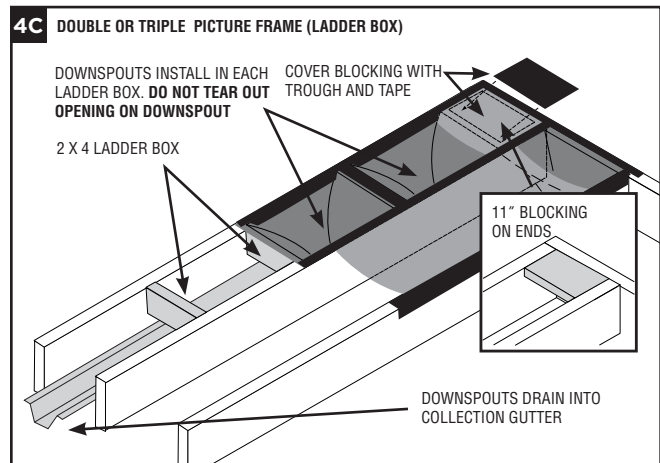
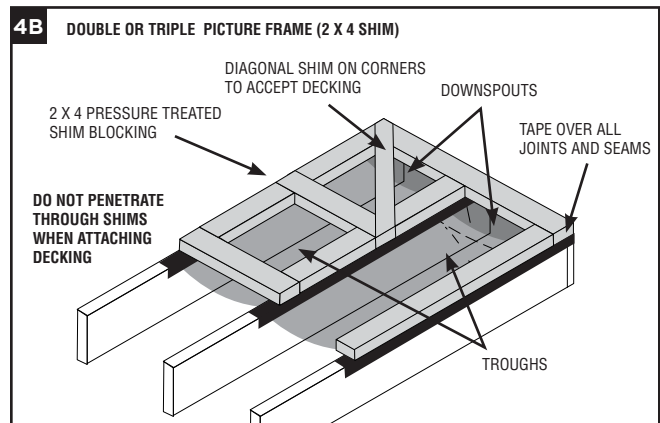



#### 4C. DOUBLE OR TRIPLE PICTURE FRAME: LADDER BOX

- » Place a 11" blocking horizontally on the ends of the bay to support 45° decking.
- » Install a 2 x 4 ladder box to support Downspouts.
- » Trim off all downspout nozzels to accommodate gutter.
- » Place Downspouts into ladder box (**DO NOT REMOVE OPENINGS**)
- » Install a piece of trough material over the 11" blocking, making sure to overlap downspouts and the adjoining trough.
- » Tape over blocking, joints and seam making sure that all screw penetrations go through trough and tape.

#### 5. CANTILEVERED DOWNSPOUT

- » Tear off the cut-out on the front panel of the downspout.
- » On the back side of the downspout draw a line from corner to corner extending down 1". Cut the downspout following the line.
- » Staple the trough material from the end of the cantilever over the existing trough. Repeat all the steps as necessary for trough installation.
- » Tape over all joints and seams.

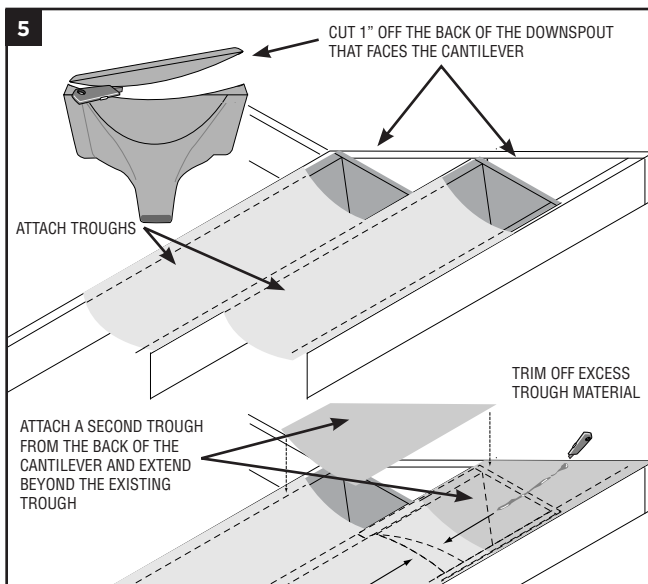

#### 6. OBSTRUCTIONS AND POSTS

- » To install a post or obstruction on the inside rim joist, first mark the edges of the post on the trough and draw two lines, corner to corner. Cut along the diagonal lines.

- » Pull up tabs and install the post.
- » Tape starting at bottom of the trough, up the post overlapping layers to assure a water tight seal, working up around the post extending down onto the trough. Cut the tape at a 45 degree angle on all corners. Place a small piece of tape over the corners where the trough and post meet, to seal the corners from any leaks.
- » Staple trough as per the previous instructions.

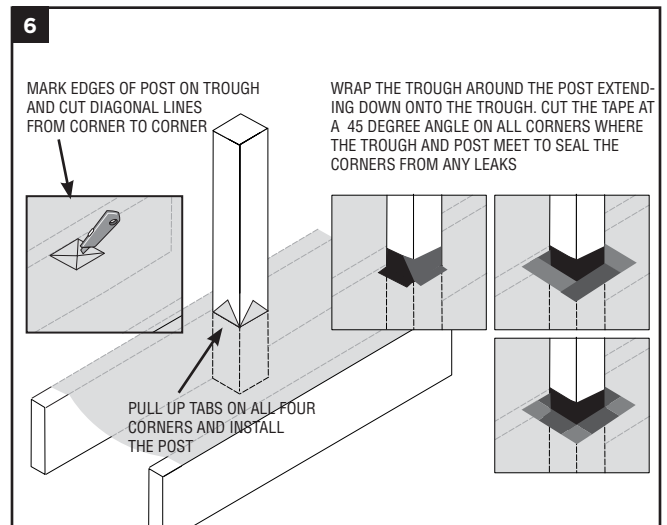

#### MODIFYING DOWNSPOUT FOR OBSTRUCTIONS

- » Trace the obstruction on the downspout and remove the material with a knife. (6A)
- » Cut a patch of trough material 2" larger than the opening and create flaps on patch as per previous instructions (obstructions and posts) and slide over the top of the obstruction. (6B)
- » Cover cut out area and post with tape. (6C)

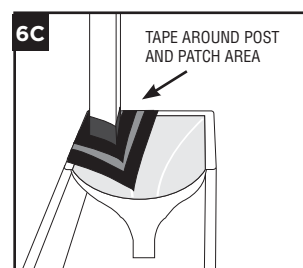
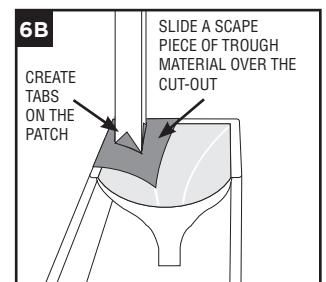
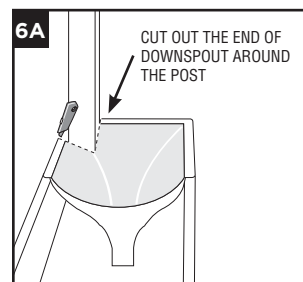

# MODIFICATIONS AND SPECIAL CASES (CONT.)

## 7. DOUBLE EXTENDED DECKS (OVER 19')

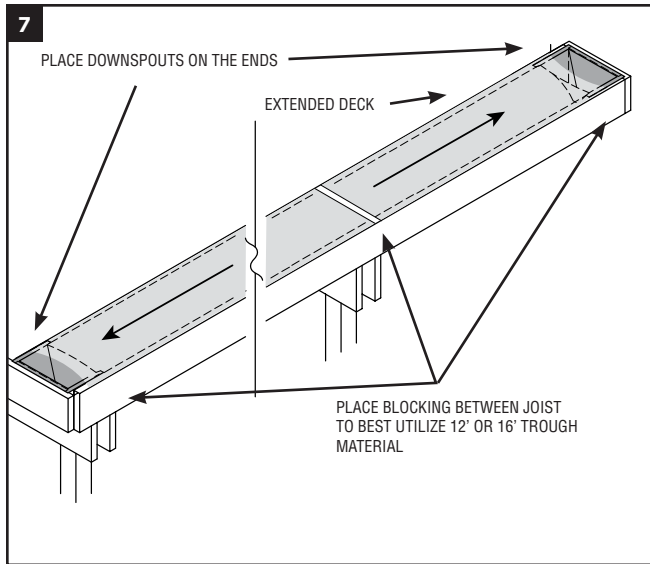

- » Place downspouts on the opposite ends from where the existing deck and the deck extension meet.
- » Install a trough from the blocking of the extension to the downspout.
- » Tape all seams and edges as per previous instructions.

## 8. LOW PROFILE CAN LIGHTS

- » When installing low profile can lights below the trough, make sure the trough is not in contact with the recessed can.

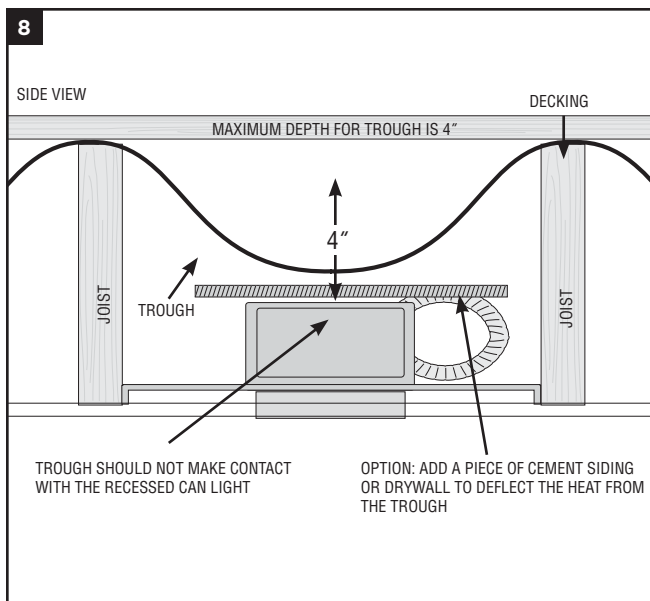

## MODIFIED DOWNSPOUTS

- » For joists 8" to 12" you must modify the downspout.
- » Tear or cut out the front opening.
- » Cut through the back of the downspout, from top to bottom.
- » Adjust the downspout to fit in the bay and staple to secure.
- » Finish by taping the seam from top to bottom.

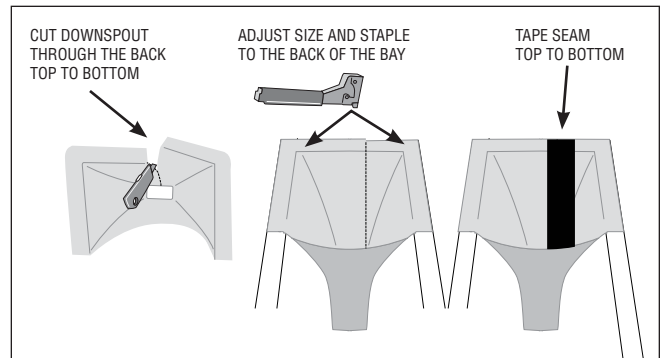

## 9. INSTALLING A TROUGH OVER A DOUBLE OR TRIPLE BEAM

- » Caulk between each beam to ensure a water tight seal between the beams.
- » Cover the top of the beam with the trough material that overlaps into both adjacent bays. Tape seams and trough material where screws penetration may occur.

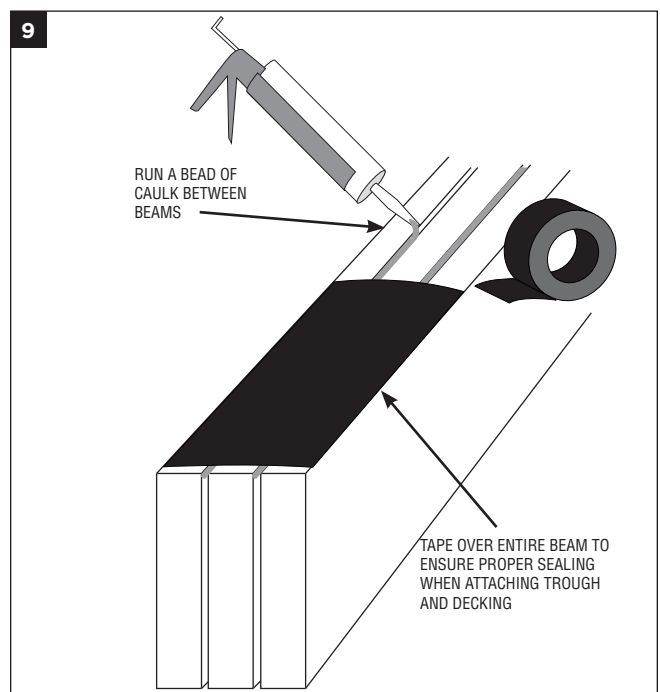

# INSTALLATION USING THE TREX ELEVATIONS™ SYSTEM

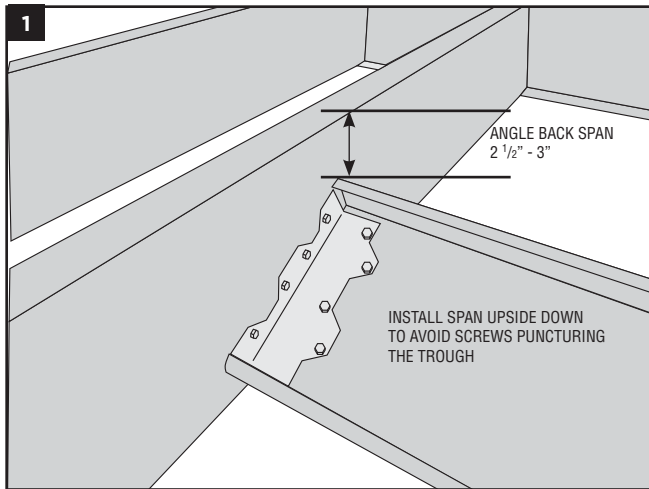

## 1. PREP

Apply blocking mid-span between joists. Blocking should be angled back to leave a minimum of 2 1/2" - 3" from the top of the joist. Turn blocking around so screws do not puncture trough. ([This blocking method only applies when using Trex® RainEscape®. For blocking instructions for a standard Trex Elevations™ see instructions for Elevations.](#))

Please note: To properly install the Trex RainEscape system over the Trex Elevations system requires a minimum of 2 people.

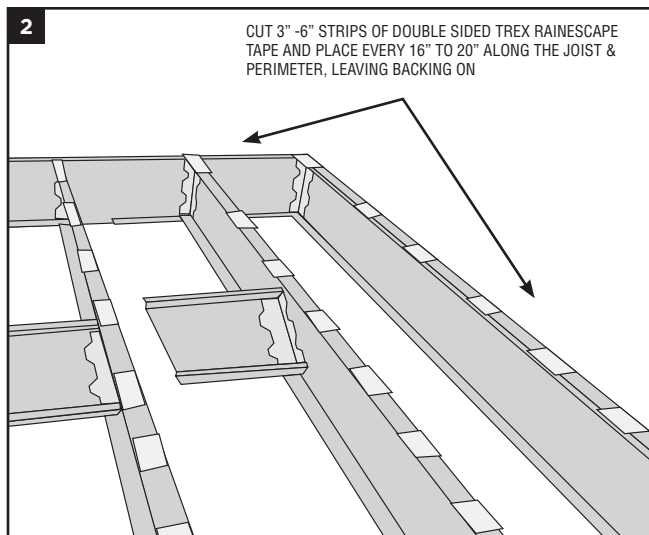

## 2. TAPE AROUND JOIST AND PERIMETER

» Cut 3" - 6" strips of the TrexRainEscape double sided tape and place every 16" - 20" along the joists and perimeter leaving backing on.

## 3. DOWNSPOUTS

- » Remove the backing on the double sided tape and place the downspout in the joist bay.
- » Repeat the process the same as you would in a standard TrexRainEscape installation.

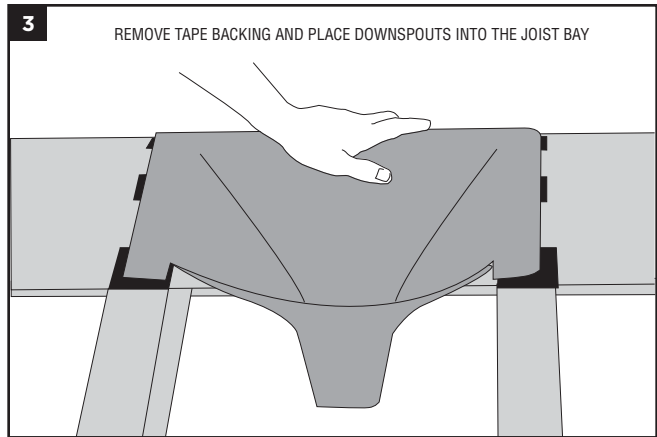

## 4. TROUGHS

- » Remove the backing on the double sided tape on one side of the joist and place the first side of the trough as you would in a standard installation.
- » Place new strips of the Trex RainEscape double sided tape along the top of the adjoining trough and install as you would in a standard installation. (4A)

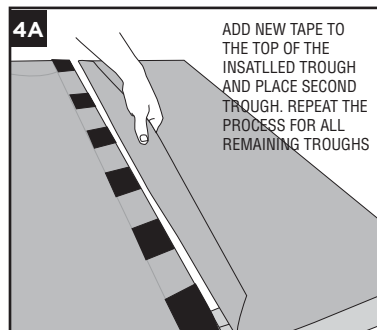
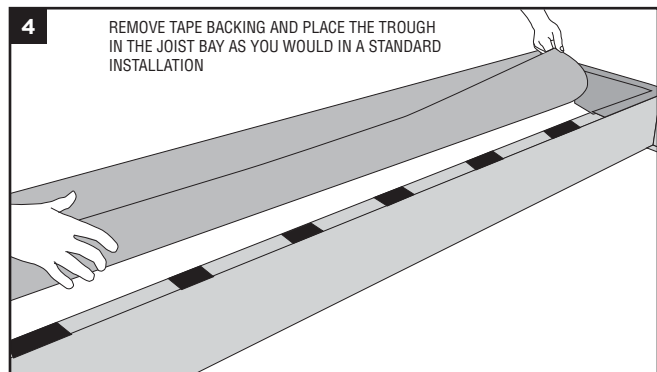

## SEALING THE SYSTEM

- » Tape the finished system as you would in a standard installation.

## Warranty

### TWENTY-YEAR WARRANTY.

**READ THESE WARRANTY TERMS CAREFULLY BEFORE INSTALLING OR USING THE TREX® RAINESCAPE® DECK DRAINAGE SYSTEM. YOUR INSTALLATION AND USE OF THE SYSTEM OR ANY OF ITS COMPONENTS INDICATES THAT YOU AGREE TO BE BOUND BY THESE TERMS. IF YOU DO NOT AGREE TO ALL OF THE TERMS OF THIS WARRANTY, RETURN THE PRODUCT TO THE PLACE OF PURCHASE FOR A FULL REFUND.**

This warranty gives you specific legal rights, and you may also have other rights which vary from State to State.

### 1. Warranty

Dri-Deck Enterprises, LLC (Dri-Deck) warrants that at the time of sale the components of the Trex RainEscape Deck Drainage System (the "System") will be free from defects in material and manufacture and will conform to Dri-Deck's specifications for the components. Dri-Deck further warrants that for a period of twenty years after sale the System will not leak, PROVIDED THAT it is installed and maintained in accordance with Dri-Deck's instructions and is not subjected to (a) alteration or unauthorized repairs, (b) misuse or abuse, such as by puncturing, cutting, burning, melting and the like, (c) Acts of God (including without limitation hurricanes, tornadoes, floods, earthquakes, or other severe weather or natural phenomena), or (d) improper storage or handling or other treatment or installations for which it was not intended. This warranty extends only to the first owner ("the Owner") of the structure on which the system is installed who uses the structure for its intended purpose---whether residential or commercial.

### 2. DISCLAIMER OF OTHER WARRANTIES

The preceding warranties are the exclusive and sole express warranties given by Dri-Deck. They supersede any prior, contrary or additional representations, whether oral or written. DRI-DECK HEREBY DISCLAIMS AND EXCLUDES ALL WARRANTIES WHETHER EXPRESS, IMPLIED, OR STATUTORY-INCLUDING ANY ARISING FROM COURSE OF DEALING OR USAGE OF TRADE, ANY WARRANTY OF MERCHANTABILITY AND ANY WARRANTY OF FITNESS FOR A PARTICULAR PURPOSE, except that for System components purchased directly by a consumer, any implied

warranties are limited in duration to the term of express warranties provided above. Some states do not allow limitations on how long an implied warranty lasts, so the above limitation may not apply to you.

### **3. EXCLUSIVE REMEDY FOR ANY NONCONFORMITIES**

If during the applicable warranty period, the System or its components do not conform to the preceding Warranties, the Owner shall notify Dri-Deck as provided below, and within a reasonable time Dri-Deck will provide, at its option, one of the following: (1) replacement components for any nonconforming or defective components or (2) the percentage of the purchase price for the non-conforming System components equal to the percentage of the warranty period remaining when Dri-Deck is notified of the nonconformity. Dri-Deck will not be liable for labor, costs of removal or re-installation of components, disposal, freight, taxes, or other incidental charges. THESE REMEDIES ARE THE EXCLUSIVE AND SOLE REMEDIES FOR ANY BREACH OF WARRANTY. For any breach of warranty, the owner must notify Dri-Deck in writing at the address in Section 7 within thirty (30) days after discovering the nonconformity. The notice must describe the location and nature of the nonconformity. The owner must give Dri-deck a reasonable opportunity to examine the claimed nonconformity before undertaking any repairs, removal or replacement. The owner must present the original invoice, bill, or other proof of date of purchase. Compliance with the requirements of this paragraph is a condition to coverage under the Warranty: if these requirements are not complied with Dri-Deck will have no obligation to provide any remedy for any breach of warranty.

### **4. DISCLAIMER OF INCIDENTAL AND CONSEQUENTIAL DAMAGES**

IN NO EVENT SHALL DRI-DECK BE LIABLE FOR ANY INCIDENTAL, SPECIAL, INDIRECT, OR CONSEQUENTIAL DAMAGES, WHETHER RESULTING FROM NONDELIVERY

OR FROM THE USE, MISUSE, OR INABILITY TO USE THE PRODUCT OR FROM DEFECTS IN THE PRODUCT OR FROM DRI-DECK'S OWN NEGLIGENCE. Some states do not allow the exclusion or limitation of incidental or consequential damages, so the above limitations may not apply to you.

### **5. APPLICABLE LAW**

This warranty will be interpreted, construed, and enforced in all respects in accordance with the Laws of the State of Colorado, without reference to its choice of law rules. The U.N. Convention on Contracts for International Sale of Goods will not apply to this warranty.

### **6. SEVERABILITY**

If any provision of this warranty is found to be invalid or unenforceable, then the remainder shall have full force and the invalid provision shall be partially enforced to the maximum extent permitted by law to effectuate the purpose of the agreement.

### **7. ADDRESS FOR NOTICES TO DRI-DECK**

Dri-Deck Enterprises, LLC  
2972 Rockbridge Drive  
Highlands Ranch, CO. 80129

## Frequently Asked Questions

**Q: Can I install the system myself?**

**A:** Yes, with the easy-to-follow instructions that come with the Trex® RainEscape® system, a pair of scissors, utility knife, staple gun and caulking gun are all you need to install the system in one or two hours on most decks.

**Q: Can I install this over an existing deck?**

**A:** Yes, but the existing deck boards must be removed while you install the Trex RainEscape System.

**Q: How do Trex RainEscape's prices compare to other similar systems?**

**A:** Although Trex RainEscape is a unique water drainage system it costs less than the nearest competitor.

**Q: How durable is the Trex RainEscape System?**

**A:** Made with durable plastic and Ultra Violet inhibitors, the Trex RainEscape system will be protected from the sun, snow and rain.

**Q: How do you clean out the debris?**

**A:** There should be very little if any debris that enters the system because it has to be small enough to fit through the decking. Small debris simply passes through the system with water. In the rare case that there is some build up, simply remove the piece of decking over the affected area and clean as needed.

**Q: Is the Trex RainEscape System affected by freezing temperatures?**

**A:** If the system is installed correctly any water that is caught drains out through the downspout in a matter of seconds. With no water remaining in the system, freezing is not an issue.

**Q: What are the overall benefits of the Trex RainEscape System?**

- 1.** It protects the structural integrity of your deck
- 2.** Easy to install
- 3.** The Trex RainEscape System allows you to create an indoor environment outdoors underneath your deck. You can install ceiling fans, speakers, video electronics and furniture that will all be safe from the elements.

**Q: If I run into problems, is there a number I can call to ask questions?**

**A:** Yes go to our website @ [trexrainscape.com](http://trexrainscape.com) or 1-800-BUY TREX

## Helpful Tips

**Snow build-up**

Snow will sit on the decking and, as it melts, will run through the system.

**Leaves**

If leaves and debris accumulate in the troughs, a standard washing or a hard rain will clean out the system.

**If the tape will not stick**

In areas, such as the perimeter, brick or stucco, where the Trex RainEscape tape will not stick, use the Trex RainEscape caulking to adhere the material.

**Caution**

Do not splice trough material. If the trough material is spliced it must be replaced. Do not try to repair any damage with the Trex RainEscape tape.



**Trex** RainEscape®  
DECK DRAINAGE SYSTEM

**COMPETITORS**

Joist protection .....	<input checked="" type="radio"/>	.....	<input type="radio"/>	.....
20-year Limited Residential Warranty .....	<input checked="" type="radio"/>	.....	<input type="radio"/>	.....
Soffit/ceiling of your choice .....	<input checked="" type="radio"/>	.....	<input type="radio"/>	.....
Recessed lighting and ceiling fans .....	<input checked="" type="radio"/>	.....	<input type="radio"/>	.....
Complete entertainment systems .....	<input checked="" type="radio"/>	.....	<input type="radio"/>	.....
Furniture .....	<input checked="" type="radio"/>	.....	<input type="radio"/>	.....
Outdoor kitchens .....	<input checked="" type="radio"/>	.....	<input type="radio"/>	.....



**Trex**<sup>®</sup>

HOW OUTDOOR LIVING SHOULD FEEL.

Visit **trex.com** or call **1-800-BUY-TREX**

© 2012 Trex Company, Inc. All rights reserved. Trex<sup>®</sup>, the Trex logo, Trex Transcend<sup>®</sup>, Trex DeckLighting<sup>®</sup>, Trex Accents<sup>®</sup>, Trex Enhance<sup>™</sup>, Trex Designer Series Railing<sup>®</sup>, Trex Hideaway<sup>®</sup>, Trex RainEscape<sup>®</sup>, Trex Trim<sup>®</sup>, Smooth Edge<sup>®</sup>, Trex Pergola<sup>™</sup>, Trex Elevations<sup>™</sup>, TrexExpress<sup>™</sup>, TrexPro<sup>®</sup>, DecksScapes<sup>®</sup> and Trex OutdoorFurniture<sup>™</sup> are either federally registered trademarks, trademarks or trade dress of the Trex Company, Inc., Winchester, Virginia.