



## Code Compliance Research Report

## CCRR-0202

Subject to Renewal: 02/21/2015  
Visit [www.ati-es.com](http://www.ati-es.com) for current status

Issued: 02/21/2014  
Page 1 of 6

**Trex Company, Inc.**  
160 Exeter Dr.  
Winchester, VA 22603  
(540) 542-6300  
[www.Trex.com](http://www.Trex.com)

### 1.0 Subject

*Trex® Reveal™* Railing

### 2.0 Research Scope

#### 2.1. Building Codes:

2012 International Residential Code (IRC)

#### 2.2. Properties:

Structural Performance

### 3.0 Description

3.1. General – The *Trex® Reveal™* railing system is a guard or guardrail under the definitions of the referenced codes. It is intended for use at or near the open sides of elevated walking areas of buildings and walkways as required by the codes.

3.2. Guard Assemblies – Guards are provided as level guards for level walking areas such as decks, balconies, and porches. Level guards are provided with rail lengths up to 96 inches in length (measured between the inside of support posts) and an installed height of 42 inches. See Table 1 for qualified configurations.

3.3. Materials and Processes - The *Trex® Reveal™* railing system is an assemblage of extruded aluminum materials, stainless steel fasteners, and cast Zamak 3 bracket materials.

3.3.1. The system is available in various colors and architectural grade powder coated finishes.

3.4. Components - The guardrail system includes a top rail, bottom rail, balusters, structural aluminum post, rail-to-post brackets, and decorative moldings and post caps.

3.4.1. Rails - Each of the top and bottom aluminum rails are routed to accept various infill components described in Section 3.4.2.

3.4.1.1. The top rail is an extruded aluminum rail with internal longitudinal ribs, dimensions of 1.75 inches wide by 1.44 inches tall. See Figure 1. A PVC rail insert is used as a baluster retainer.

3.4.1.2. The bottom rail is an extruded aluminum rail with internal longitudinal ribs, dimensions of 1.75 inches wide by 1.25 inches tall. See Figure 2. A PVC rail insert is used as a baluster retainer.

3.4.2. The infill area utilizes aluminum square or round balusters (See Figure 3).

3.4.3. Aluminum post supports consist of a 2.5 inch square by 0.125 inch wall extruded aluminum tube. The tube is connected to a 4 inch square by 1/2 inch thick aluminum base plate via a 1/4 inch continuous fillet weld on all four sides. See Figure 7.

3.4.4. A support block is installed between the lower rail and the deck surface midway between supports. See Figure 5.

### 4.0 Performance Characteristics

4.1. The guardrail system described in this report has demonstrated the capacity to resist the design loadings specified in Section R301 of the IRC when tested in accordance with ICC-ES AC273.

### 5.0 Installation

The guardrail system shall be installed in accordance with the Trex Company, Inc.'s installation instructions and this report. Where differences occur between this report and the manufacturer's installation instructions, this report shall govern.

5.1. The top and bottom rails are attached directly to structural posts utilizing cast Zamak 3 mounting brackets via mechanical fasteners. See Figure 6 and Table 2.

5.2. Aluminum balusters are inserted into routed holes in the aluminum rails and secured via PVC rail inserts that are installed internally to the rails. See Figure 3 and 4.

5.3. Four shim plates are utilized under the base of the 2.5 inch aluminum post mount. The shim plates line the perimeter of the post base. Shim plates are 3.5 inches long by 0.75 inches wide by 0.01 inch thick stainless steel plates. See Figure 8.



5.4. *Trex® Reveal™* railing systems are attached to 2.5" square aluminum post mounts which may be surface mounted to a wood deck.

5.4.1. The *Trex® Reveal™* 2.5 inch post mount may be mounted to a wood deck in accordance with the details in Figure 8.

5.4.1.1. A minimum of four 3/8 inch diameter, 6 inch long anchor bolts must be used and located in the four pre-drilled holes in the structural post base plate.

5.4.1.2. Pressure-treated 2x8 Southern Yellow Pine (specific gravity 0.50 or better) boards are used as blocking under the post location and are fastened between the joists with #10 x 3 inch wood screws in accordance with the National Design Specification for Wood Construction (ANSI/AWC NDS-2012). See Figure 8 for spacing and quantities.

5.4.1.3. A 1/4" thick, 4.5 inch square steel back plate is installed on the underside of the wood blocking as illustrated in Figure 8.

5.4.1.4. Decking shall be *Trex® Transcend®* deck boards (solid or grooved) or decking equivalent in compressive strength. Hollow, ribbed or decking that is of less compressive strength is not suitable for post mount installation.

## 6.0 Supporting Evidence

6.1. Drawings and installation instructions submitted by Trex Company, Inc.

6.2. Reports of testing demonstrating compliance with the performance requirements of ICC-ES AC273, Acceptance Criteria for Handrails and Guards, effective March 1, 2008 (editorially revised Jan. 2012).

6.3. A quality control manual that is in accordance with the ICC-ES AC10, Acceptance Criteria for Quality Documentation, approved June 2012.

## 7.0 Conditions of Use

The guard assemblies identified in this report are deemed to comply with the intent of the provisions of the referenced building codes subject to the following conditions.

7.1. Attachment of guardrail systems described herein to conventional wood supports is outside the scope of this report.

7.2. Where required by the building official, engineering calculations and details shall be provided. The calculations shall verify that the anchorage and supporting structure complies with the building code for the type and condition of the supporting construction.

7.3. Stainless steel shim plates are used to prevent direct contact between the structural post base plate and supporting structure.

7.4. Compatibility of fasteners and other metallic components with the supporting structure, including chemically treated wood, is outside the scope of this report.

7.5. The *Trex® Reveal™* railing system is manufactured in accordance with an approved quality control system that includes independent third party inspections by NTA, Inc. (IAS AA-682) and PFS Corp. (IAS AA-652).

## 8.0 Identification

The *Trex® Reveal™* railing guardrail assemblies that are described in this report shall be identified with labeling on the individual components and/or the packaging such that the product is identifiable at the point of use. The label shall include at least the following information:

8.1. Name and/or trademark of the manufacturer

8.2. The name and/or identifying mark of the independent inspection agency.

8.3. The label shall also include the phrase: "For Use in One- and Two-Family Dwellings Only".

8.4. The Architectural Testing Code Compliance Research Report mark and number (CCRR-0202).

## 9.0 Code Compliance Research Report Use

9.1. Approval of building products and/or materials can only be granted by a building official having legal authority in the specific jurisdiction where approval is sought.

9.2. Code Compliance Research Reports shall not be used in any manner that implies an endorsement of the product by Architectural Testing.

9.3. Reference to the Architectural Testing internet web site address at [www.ati-es.com](http://www.ati-es.com) is recommended to ascertain the current version and status of this report.

**Table 1 – Code Occupancy Classification**

Guardrail System	Type	Maximum Guardrail Dimensions <sup>(1)</sup>	Support Post Mount System		Code Occupancy Classification
Trex® Reveal™ Railing System	Level	96 inches by 42 inches	2.5 inch Aluminum Post Mount (Figure 7)	Mounted to surface of wood deck <sup>(2)</sup>	The use of this product shall be limited to exterior or interior use as a guard system for dwellings constructed in accordance with the IRC (1 & 2 Family Dwellings).

<sup>(1)</sup> Guardrails are qualified up to and including the listed maximum guardrail system dimensions for use in the referenced Code Occupancy Classification. Guardrail lengths are actual railing lengths, i.e. clear space between supports for level rails. Guardrail height is walking surface to top of top rail. Minimum installed height shall be 36 inches.

<sup>(2)</sup> The 2.5 inch aluminum post mount attachment to surface of wood deck must be in accordance with the wood deck support blocking as depicted in Figure 8. Decking shall be Trex® Transcend® deck boards (solid or grooved) or decking equivalent in compressive strength. Hollow, ribbed or decking that is of less compressive strength is not suitable for post mount installation.

**Table 2 – Trex® Reveal™ Fastener Schedule**

Connection	Fastener
Top Rail Bracket to Post	Three #10-16 by 5/8 inch pan-head, self-drilling stainless steel screws
Bottom Rail Bracket to Post	Two #10-16 by 5/8 inch pan-head, self-drilling stainless steel screws
Top Rail Bracket to Rail	
Bottom Rail Bracket to Rail	One #10-16 by 5/8 inch pan-head, self-drilling stainless steel screws
Picket to Rail	The picket at the midpoint of rail length is attached to the top and bottom rails using two #8-15 x 1.25 inch pan-head, stainless steel screws through screw bosses.
Foot Block to Bottom Rail	One #12-11 by 1.25 inch pan-head self-drilling stainless steel screws

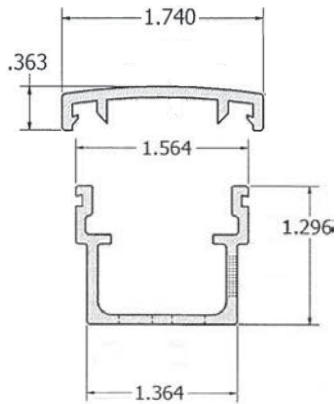

**Figure 1 – Top Rail**

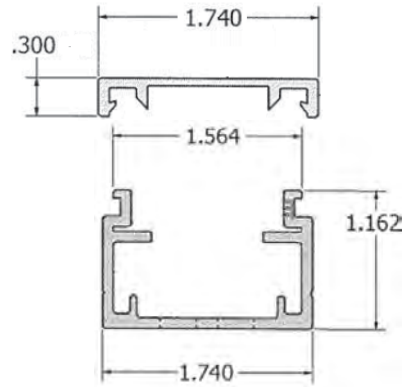

**Figure 2 – Bottom Rail**

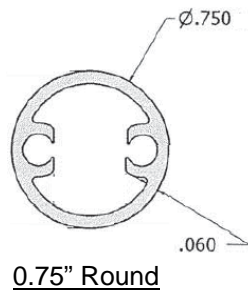

0.75" Round

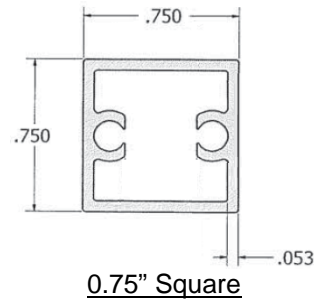

0.75" Square

**Figure 3 – Aluminum Balusters**

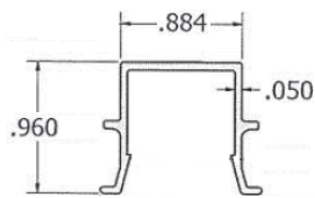

**Figure 4 – PVC Rail Insert**

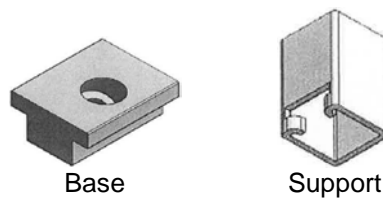

Base

Support

**Figure 5 – Two Piece Railing Support**

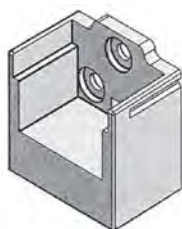

Top Mount

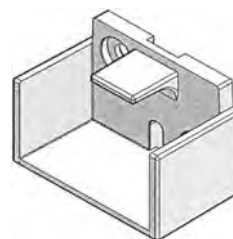

Bottom Mount

**Figure 6 – Zamak 3 Cast Mounting Brackets**

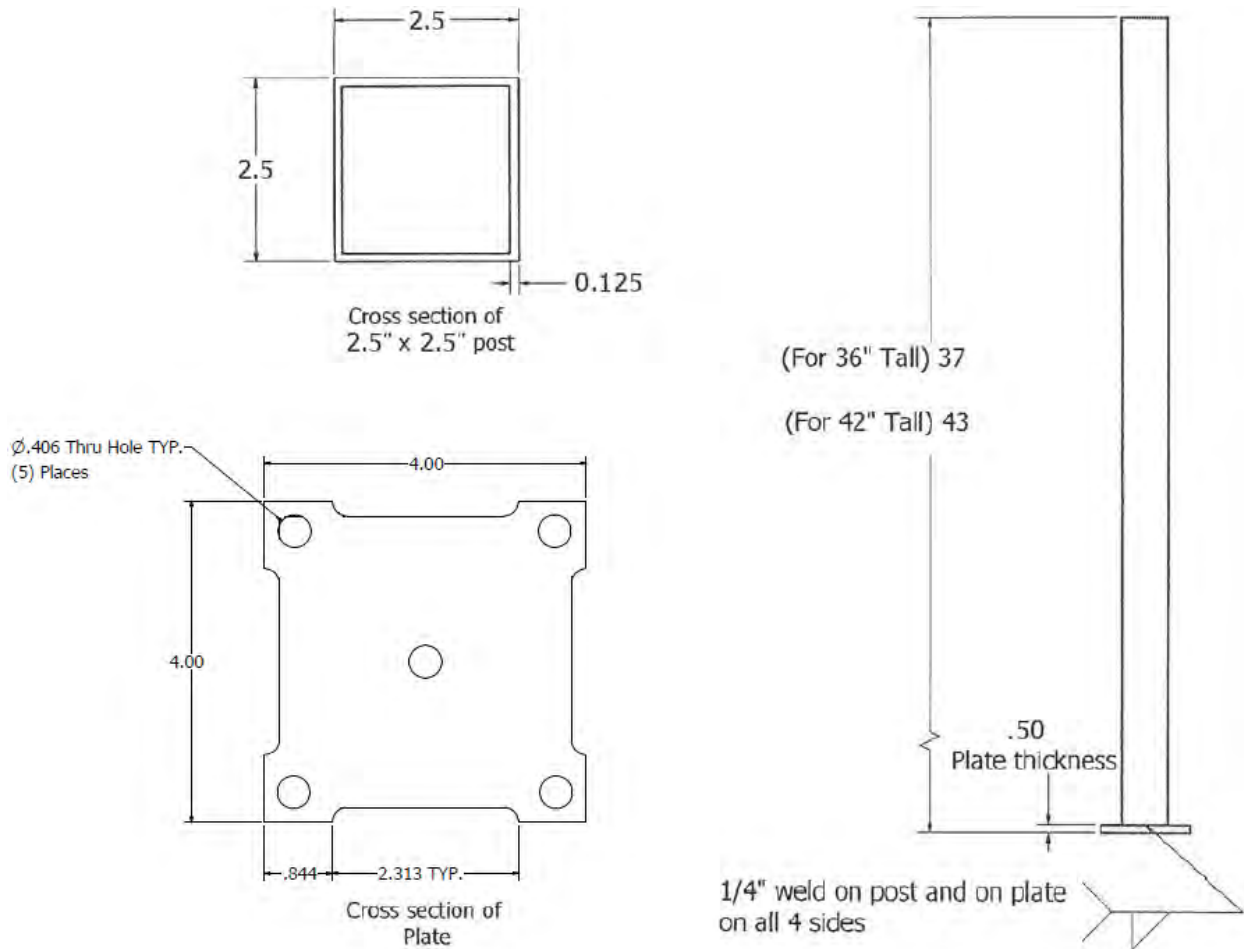

**Figure 7 – 2.5 inch square Aluminum Support Post**

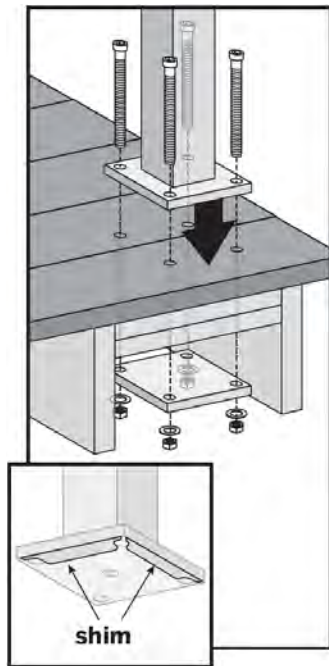

Wood deck install detail

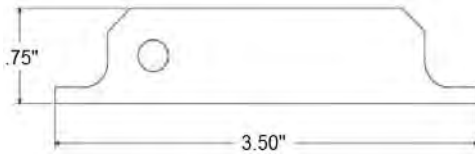

Stainless Steel Shim Plates

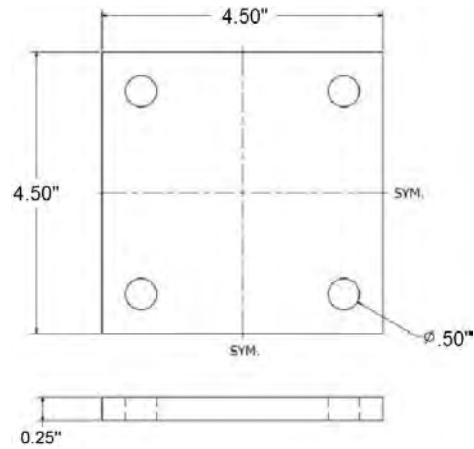

Steel Back Plate

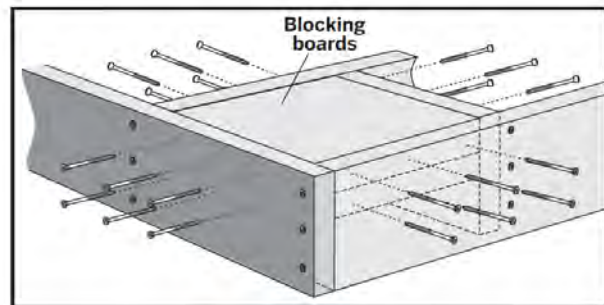
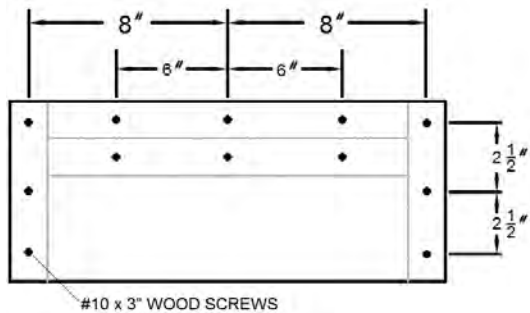
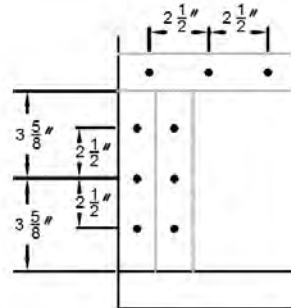
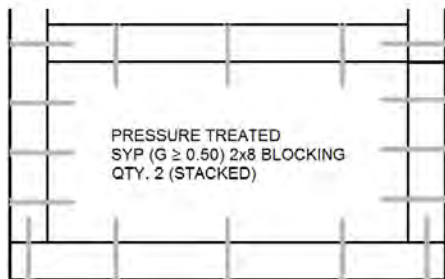

Wood blocking detail

**Figure 8 – Post Mount Installation on Wood Deck**