





Assembly Instructions





DTVIEPTT & DTVIEPTB RECT TABLE TOP - VIENNA MERLOT & RECT TABLE BASE - VIENNA MERLOT

Thank you for purchasing this quality product. Be sure to check all packing materials carefully for small parts, which may have come loose inside the carton during shipment. Identify and count all parts and compare with the **HARDWARE LIST** below.

Caution: Please read instructions thoroughly before unpacking assembly parts.

1. We recommend that you assemble this product with the assistance of another person; this will make assembly easier, and will help to eliminate damage to the product or injury to persons during assembly.
2. Please do not over tighten screws or bolts until the assembly is completed.
3. Please put all parts on a non-abrasive floor before assembly, and follow the assembly steps to assemble your newly purchased product correctly and efficiently.

NO.	Parts List	Q' TY
A	 Top panel	1
B	 Connective panel	1
C	 Post	2
D	 Bottom frame	2
E	 Center leaf	2

NO.	Hardware List	Q' TY
1	 Φ 5/16" * 18*2"L Allen Bolt	8
	 Φ 5/16" * Φ 13mm Spring washer	8
	 Φ 5/16" * Φ 22mm*2mmT Flat washer	8
	 Allen wrench (4mm)	1
	 Allen key (4mm)	1
2	 Φ 5/16" * 18*2"L Allen Bolt	8
	 Φ 5/16" * Φ 13mm Spring washer	8
	 Φ 5/16" * Φ 22mm*2mmT Flat washer	8
3	 Φ 5/16" * 18*2"L Allen Bolt	8
	 Φ 5/16" * Φ 13mm Spring washer	8
	 Φ 5/16" * Φ 22mm*2mmT Flat washer	8

TOOLS REQUIRED (NOT PROVIDED)

PHILLIPS SCREWDRIVER 

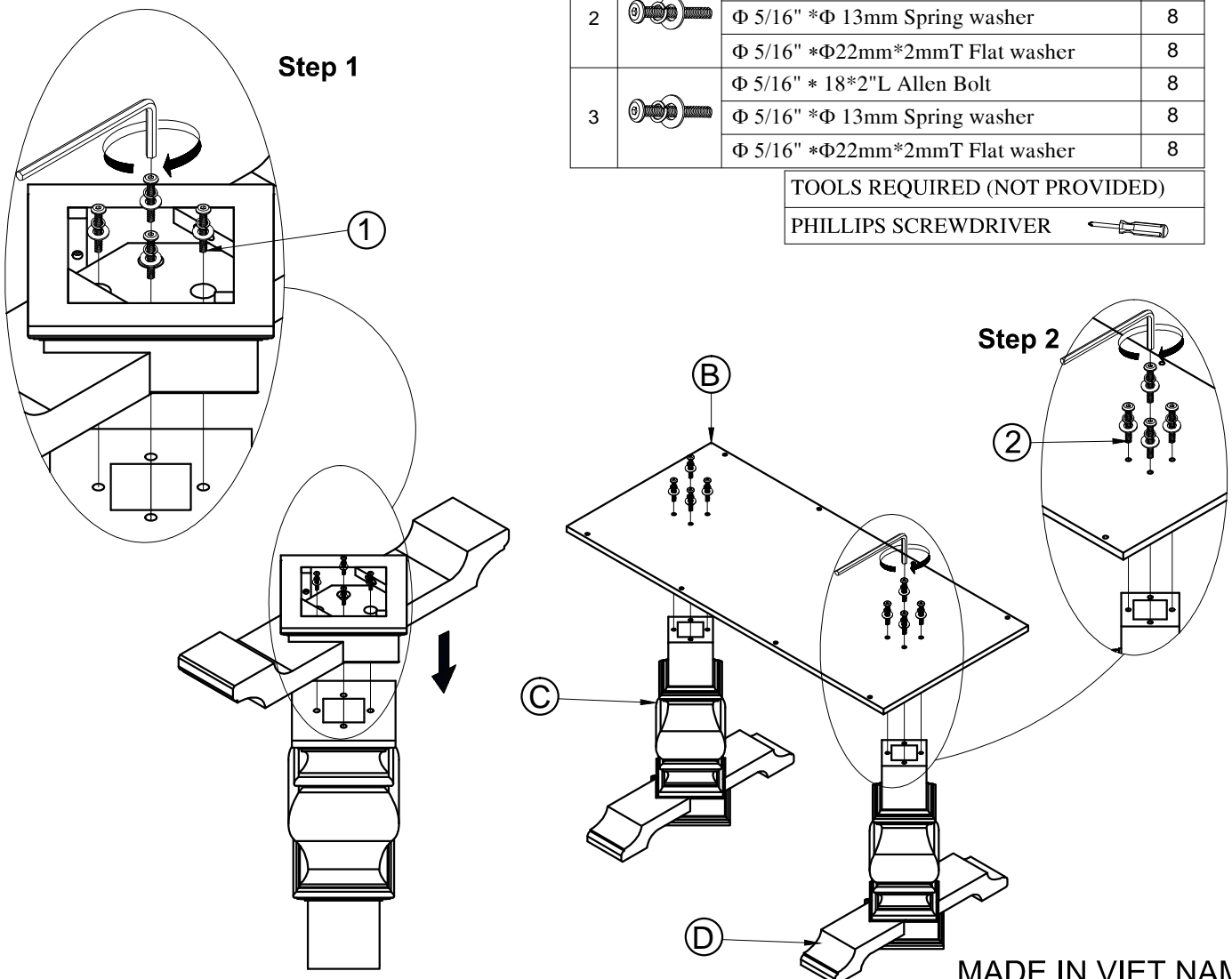

MADE IN VIET NAM

Assembly Instructions

DTVIEPTT & DTVIERTT
RECTANG TABLETOP - VIENNA MERLOT &
RECTANG TABLE BASE - VIENNA MERLOT

Step 3

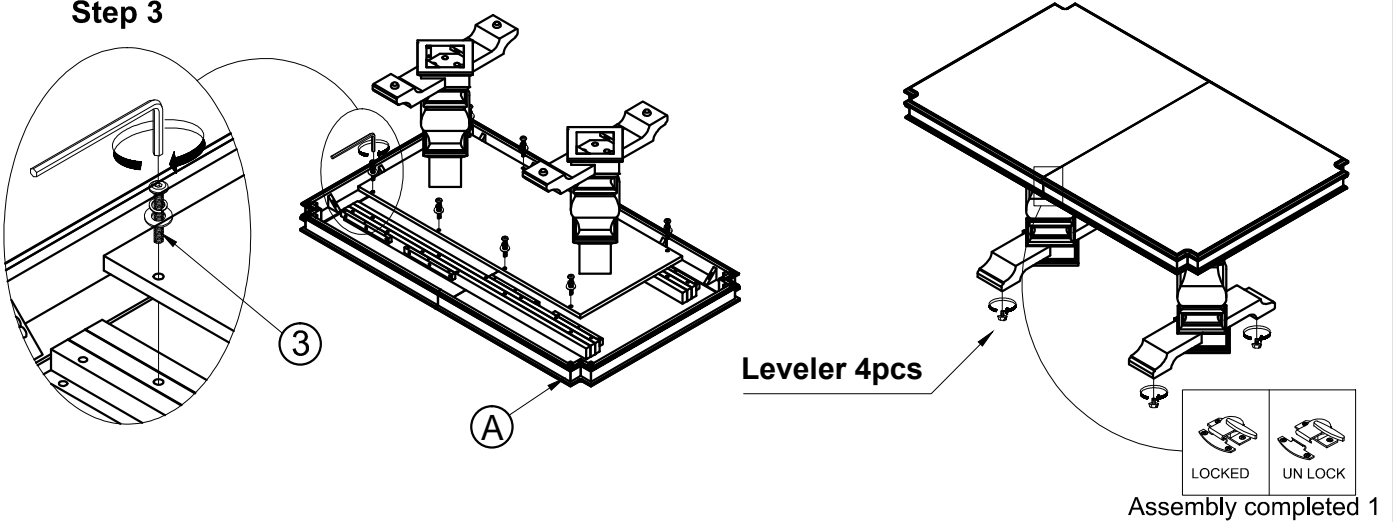

Step 4

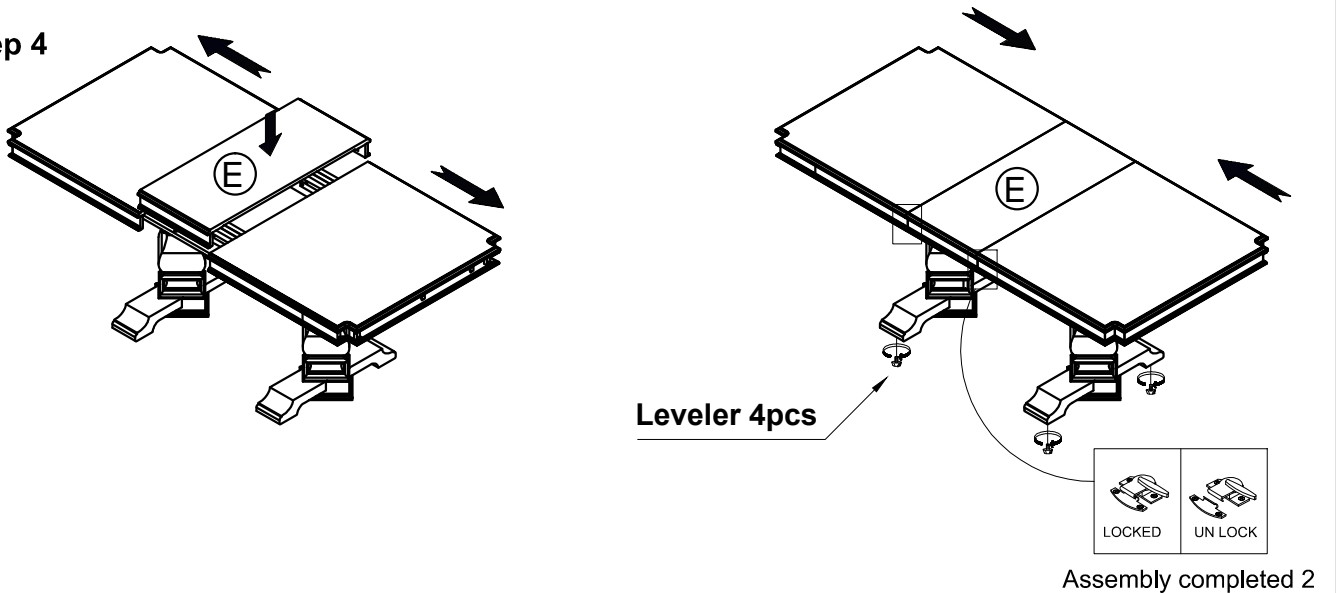

Step 5

