

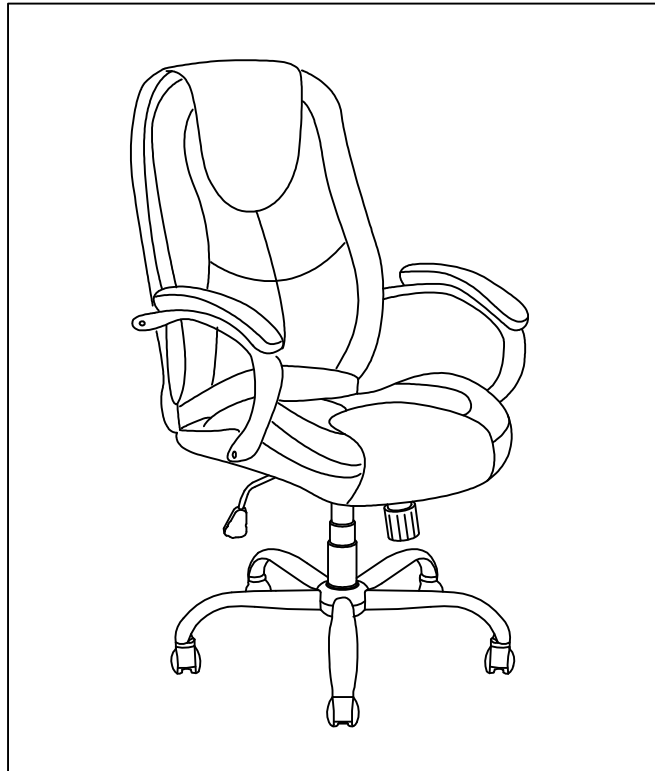

EXECUTIVE CHAIR-VIPER

VC2333ECU



 **DO NOT return to the store if parts are missing or damaged.**







For Parts Replacements and Inquiries, please call us Toll-Free 1-888-736-2141 or E-mail CustomerService@Z-LineDesigns.com

To ensure a timely delivery, please include the following:

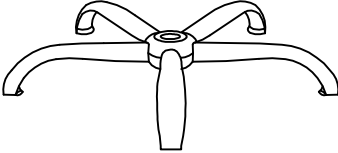

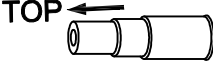
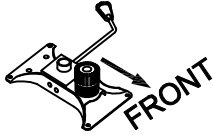

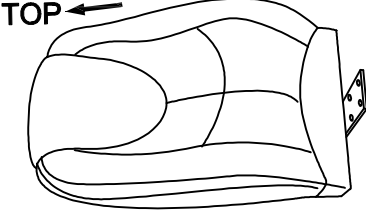

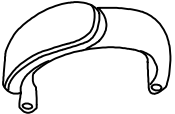

1. Full Name
2. Physical Address (Our primary carrier, FedEx, will NOT deliver to P.O. Boxes)
3. Phone Number
4. QC Number: BT
5. Item Number: VC2333ECU
6. Part Number(s) or Letter(s)
7. Quantity
8. We also request that you please provide a brief description of the reason for your request.

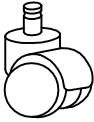
Our Customer Service Representatives will be available to assist you Monday – Friday 7:00 am to 3:30 pm Pacific Standard Time (Except Holidays).

Thank you for purchasing this quality product. Be sure to check all packing materials carefully for small parts that may have come loose inside the carton during shipment.

PARTS LIST:			
No.	Description	Sketch	Quantity
1	STAR BASE		1 PC
2	CYLINDER COLUMN		1 PC
3	COLUMN LIFT COVER		1 PC
4	CONTROL MECHANISM		1 PC
5	SEAT		1 PC
6	BACK FRAME		1 PC
7	LEFT ARM		1 PC
8	RIGHT ARM		1 PC

HARDWARE LIST:

No.	Description	Sketch	Size	Quantity
A	CASTER			5 PCS
B	ALLEN BOLT		6x30mm	6 PCS
C	ALLEN BOLT		6x20mm	2 PCS
D	ALLEN WRENCH		5mm	1 PC
E	WASHER			4 PCS
F	ALLEN BOLT		8x50x14mm	4 PCS
G	SIDE END CAP			4 PCS
H	STRAIGHT ALLEN WRENCH		5x102mm	1 PC

NOTE: Straight Allen Wrench (H) is for use with a power drill.

ASSEMBLY INSTRUCTION

STEP 1

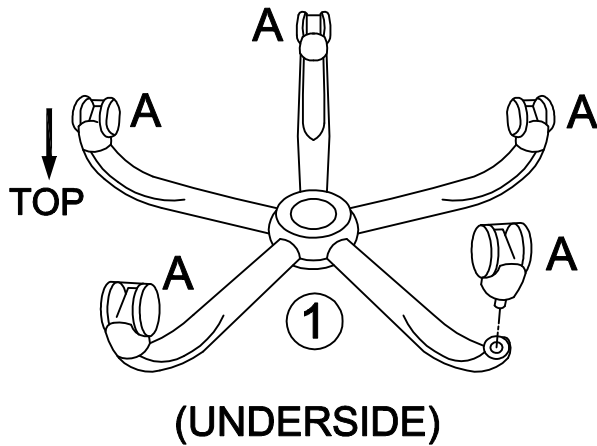

1. Insert (A) Casters into (1) Star Base until they snap into place.
2. Flip the Star Base over for the next step.

STEP 2

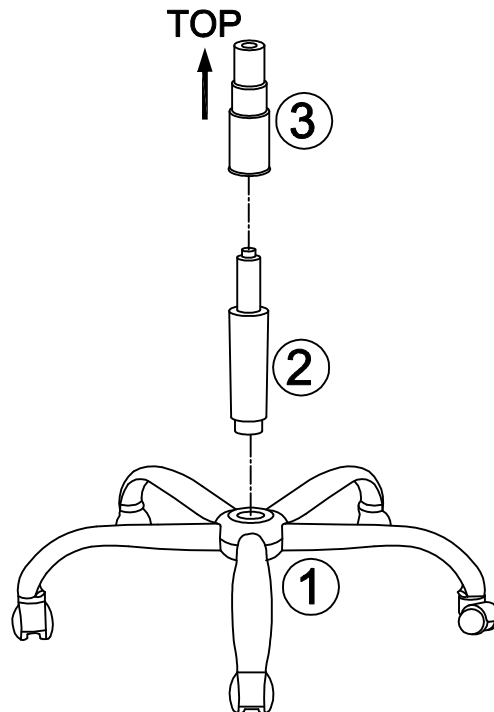

1. Insert the **LARGE** end of (2) Cylinder Column into the Star Base and carefully press downward with moderate force until it is fully seated.
2. Now slide (3) Column Lift Cover over (2) Cylinder Column, making sure the larger portion is on the **BOTTOM** as shown.
3. Set aside until Step 6.

STEP 3

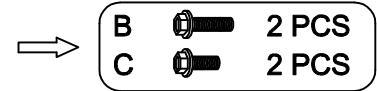
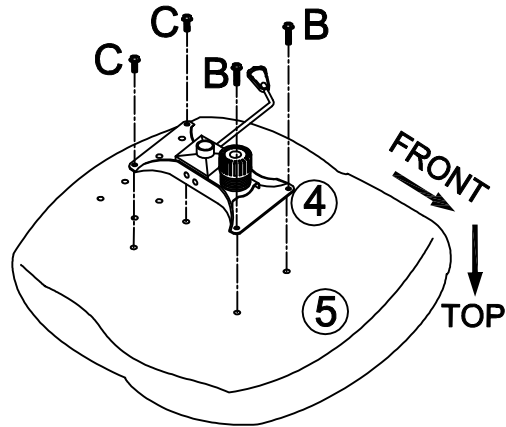

(UNDERSIDE)

DO NOT FULLY TIGHTEN BOLTS UNTIL STEP 5.

Secure (4) Control Mechanism to (5) Seat with (B) 6 x 30mm Allen Bolts, (C) 6 x 20mm Allen Bolts as shown.

***NOTE: Make sure to LINE UP the holes that connect (6) Back Frame (in Step 4).**

STEP 4

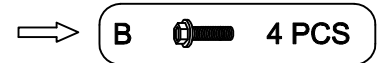
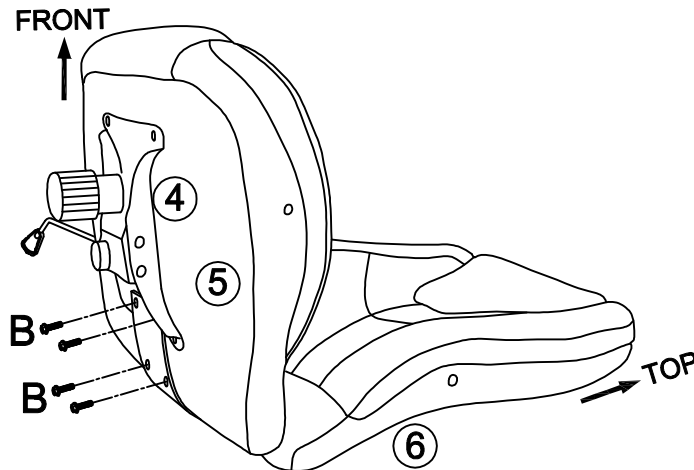

DO NOT FULLY TIGHTEN BOLTS UNTIL STEP 5.

1. Secure (6) Back Frame to (4) Control Mechanism and (5) Seat with (B) 6 x 30mm Allen Bolts.
2. Turn the assembled unit UPRIGHT before proceeding to the next step.

STEP 5

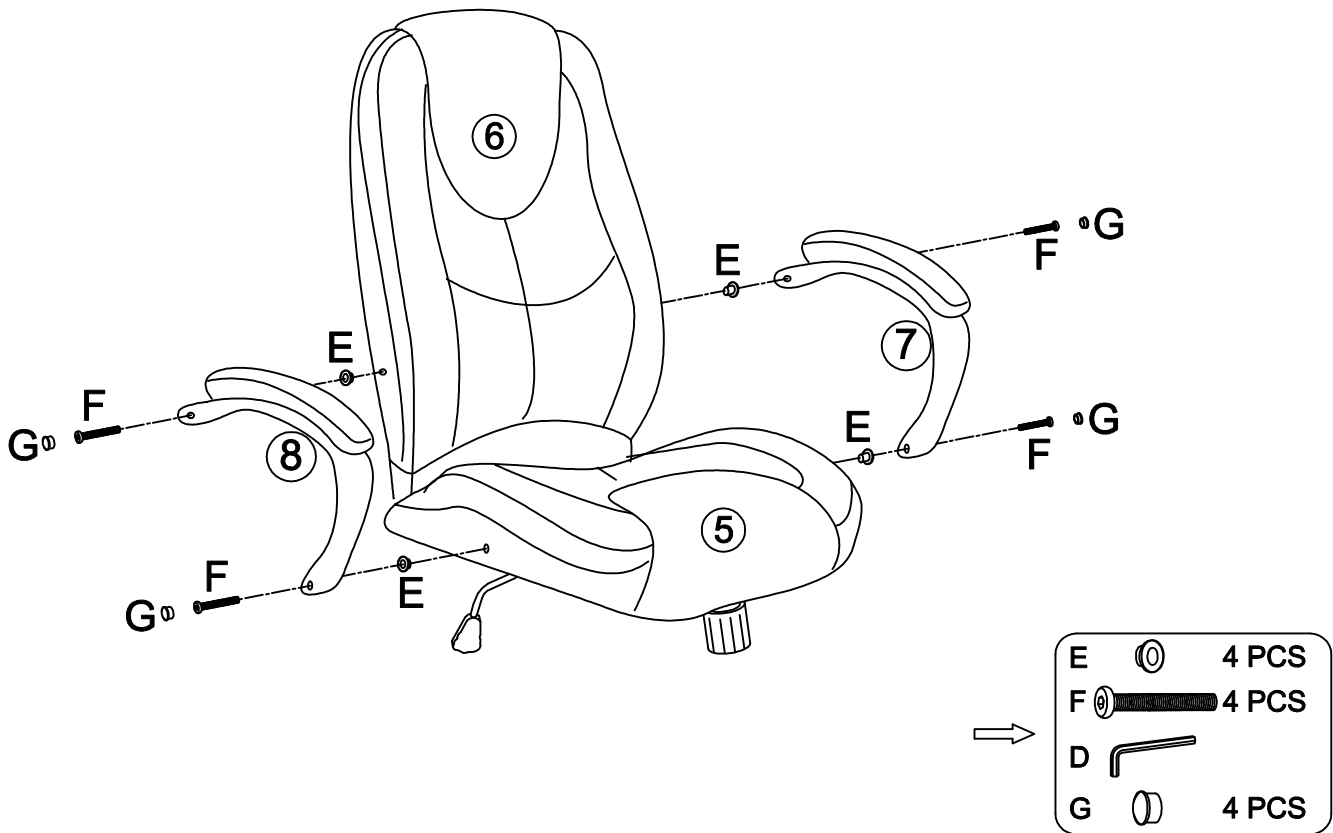

1. Secure (7) Left Arm and (8) Right Arm to (5) Seat and (6) Back Frame with (E) Washers, (F) 8 x 50 x 14mm Allen Bolts and (D) Allen Wrench.

2. **FULLY TIGHTEN ALLEN BOLTS FROM STEPS 3-4 AT THIS TIME WITH (D) ALLEN WRENCH.**

3. Install (G) Side End Caps to the ends of (7) Left Arm and (8) Right Arm as shown.

STEP 6

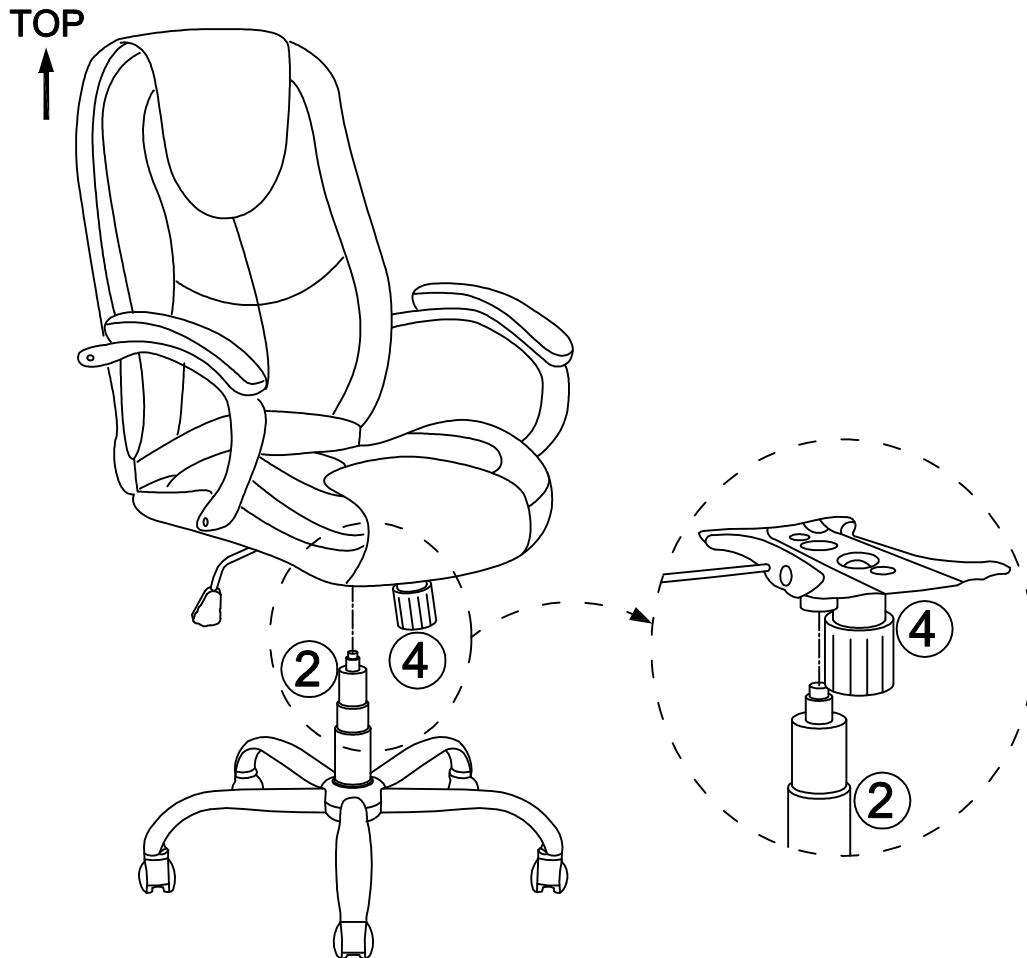

Now insert the **SMALL** end of (2) Cylinder Column into (4) Control Mechanism and **CAREFULLY** press downward with moderate force until it is fully seated.

CONGRATULATIONS, YOUR EXECUTIVE CHAIR-VIPER IS NOW COMPLETE!

MADE IN CHINA

Page 7 of 9

CONTROL MECHANISM SUPPLEMENT

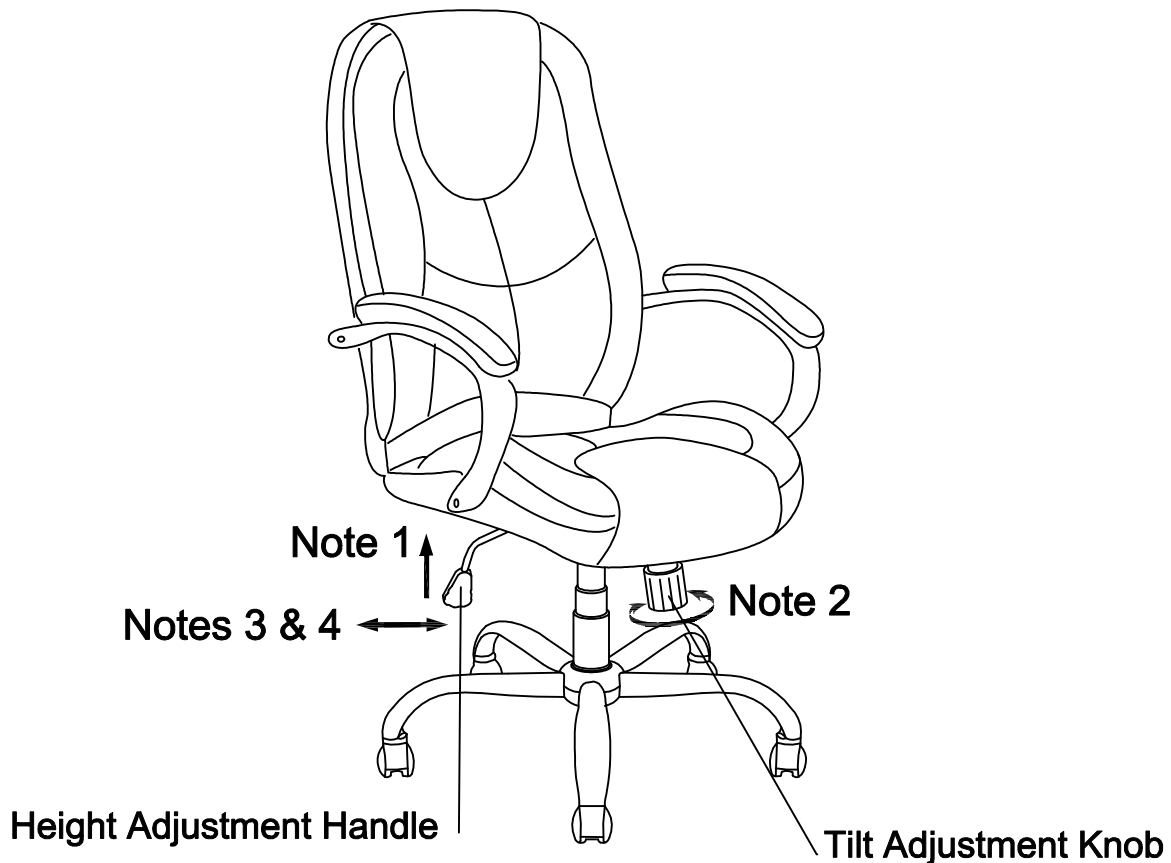

***NOTE 1:** While seated, lean forward, lifting your body weight from the seat. Reach underneath the right side of the chair and locate the Height Adjustment Handle. Lift the handle up slowly to allow the chair to rise to the desired height. To lower the seat height, lift the handle slowly while seated.

***NOTE 2:** Use the Tilt Adjustment Knob to control how far back your chair will lean.

***To ALLOW** free movement, rotate the Tilt Adjustment Knob toward the LEFT.

***To INHIBIT** free movement, rotate the Tilt Adjustment Knob toward the RIGHT.

***NOTE 3:** Push the Height Adjustment Handle INWARD to lock your chair in the UPRIGHT position.

***NOTE 4:** Pull the Height Adjustment Handle OUTWARD in order to allow your chair to lean back as far as the Tilt Adjustment Knob permits.

MAXIMUM WEIGHT CAPACITY

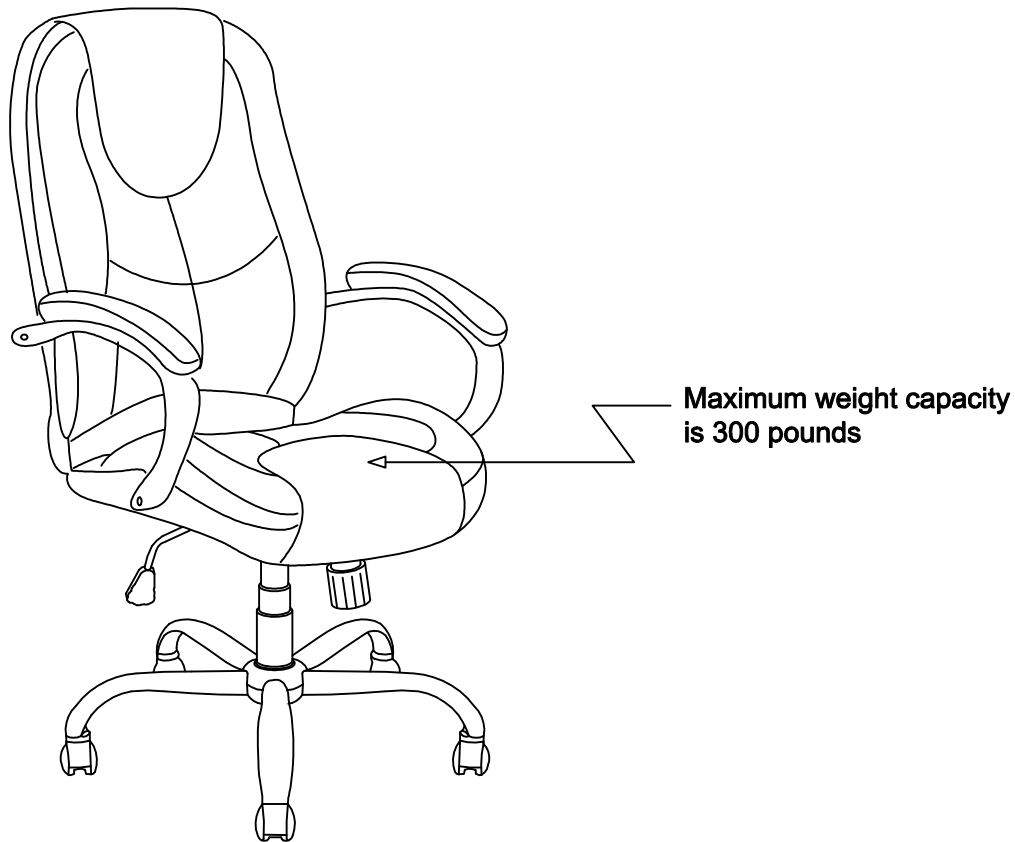

⚠ CAUTION: This product is intended to hold the Maximum Weight indicated. Exceeding the Maximum Weight will result in instability and may cause possible injury.

WARNING

- Do not stand on this chair. Do not use this chair as step ladder.
- Use this product only for seating one person at a time.
- Do not use this chair unless all bolts, screws and knobs are firmly secured.
- At least every 4 months, check all bolts, screws and knobs to be sure they are tight.
- If parts are missing, broken, damaged or worn, stop use of the product until repairs are made, using factory authorized parts.
- Failure to follow these warnings could result in serious injury.



Creating beauty, Manufacturing great value!



1 Year Limited Warranty

Thank you for purchasing a Z-Line Designs product. We promise to repair or replace any Z-Line Designs product or component that may have any defects in material or workmanship for as long as you, the original purchaser, own it. This warranty is subject to the provisions below. Z-Line Designs' sole obligation and purchasers' exclusive remedy pursuant to these warranties are limited to replacement at Z-Line Designs sole discretion. There are no other warranties except as expressly set forth below, either expressed or implied, including any warranty of merchantability for any particular purpose.

The word defects in this warranty is defined as imperfections that impair the service, function or effectiveness of the product.

1 YEAR:

Glides, casters and user-adjustable work surface mechanisms, laminates, veneer finishes and other materials which cover your Z-Line Designs product.

INFORMATION ON COLOR VARIATIONS & FINISHES:

Some natural variations occurring in wood, or other natural materials are inherent to their character, and thus can not be avoided. Therefore they are not considered to be defects. Z-Line Designs does not warrant the color-fastness or matching of colors, grains, textures or other such materials. Customers' own materials selected by and used at the request of a user is therefore not warranted by Z-Line Designs.

LIMITATIONS INVOLVING MATERIALS & COMPONENTS:

The materials and all components listed below are covered according to the following schedule from the date of sale to the original purchaser.

EXCLUSIONS:

This warranty does not apply to: damage caused by the carrier, modifications to the product, or attachments to the product not approved by Z-Line Designs, non-standard materials selected by and used at the request of a user, and products that were not installed, used or maintained in accordance with product instructions and warnings. Nor shall Z-Line Designs have any responsibility for incidental or consequential damages resulting from the breach of this Warranty, including but not limited to inconvenience, rental or purchase of replacement products, loss of profits or commercial loss. Some states do not allow the exclusion or limitation of incidental or consequential damages so the above limitation or exclusion may not apply to you. This warranty gives you specific legal rights and you may also have other rights, which may vary from state to state. This warranty applies only to products sold within the United States of America and the Commonwealth of Canada.

TO OBTAIN SERVICE FROM THIS WARRANTY:

Your Z-Line Designs' dealer is our mutual partner in supporting your warranty requests. By following the procedures instructed below, you are assured that you will receive the best level of customer service guaranteed.

- A) Please contact the local Dealer from whom you originally purchased within 30 days (**unless otherwise noted by the Dealer**) of discovery of the defect. Prepare to confirm that you are the original purchaser of the product and provide necessary product information, such as serial number(s)/UPC number(s) from the product in question.
- B) The Dealer will gather all the pertinent information required regarding your claim(s), inspect the product and thus contact a Z-Line Designs Customer Service Representative. (Please allow a reasonable amount of time for inspection, review, and response to Dealer.
- C) If the Z-Line Designs Dealer confirms that the product in review is eligible under the warranty conditions as stated above, the customer service representative or another representative of the Company will determine whether to provide replacement parts, or authorize other arrangements at the sole discretion of the vendor, Z-Line Designs. No assembly/labor is included in this warranty.

TO CONTACT CUSTOMER SERVICE:

Our knowledgeable Service Representatives are ready to assist you in the case this warranty applies to you. Please be prepared to explain the defect in detail, model/style number, date and location of purchase, your name, address, phone number and have your original sales receipt.

Please contact us Monday-Friday (except all major holidays) at:

Toll Free 1-888-736-2141 from 7:00 am – 3:30 pm (Pacific Standard Time) OR Email us: customerservice@z-linedesigns.com

OR

Contact your local dealer from whom you originally purchased the product in question.

MADE IN CHINA

