



ASSEMBLY INSTRUCTIONS
ITEM NO:WA-8214-KB
DESCRIPTION:KING UPH
BED-AVERY BLACK VELVET

Thank you for purchasing this quality product. Be sure to check all packing material carefully for small parts that may have come loose inside the carton during shipment.

TOOL REQUIRED (NOT PROVIDED):
PHILLIPS SCREW DRIVER



PARTS LIST:

No.	Description	Sketch	Quantity
A	Headboard		1PC
B	Right Headboard Leg (WITH "R" LABEL)		1PC
C	Left Headboard Leg (WITH "L" LABEL)		1PC
D	Footboard		1PC
E	Footboard Leg		2PCS
F	Side Rail with Hole on Right		2PCS
G	Side Rail with Hole on Left		2PCS
H	Side Rail Support Leg		2PCS
I	Slat	1942mm x 45mm x 18mm	4PCS
J	Support Leg	167mm x 30mm x 30mm	8PCS

HARDWARE LIST:

No.	Description	Sketch	Size	Quantity
K	JCBB SCREW		M8 x 20mm	8PCS
L	JCBC SCREW		M6 x 25mm	8PCS
M	JCBC SCREW		M6 x 35mm	14PCS
N	JCBC SCREW		M6 x 70mm	2PCS
O	WOOD DOWEL		M8 x 30mm	2PCS
P	SPRING WASHER		M6 x 13mm	14PCS
Q	FLAT WASHER		M6 x 19mm	14PCS
R	SCREW		M4 x 32mm	8PCS
S	ALLEN KEY		M4 x 100mm	1PC
T	ALLEN KEY		M5 x 65mm	1PC
U	STRAIGHT ALLEN KEY		M4 x 100mm	1PC
V	STRAIGHT ALLEN KEY		M5 x 100mm	1PC

Note: Straight Allen Key (U) & (V) are for use with a power drill.

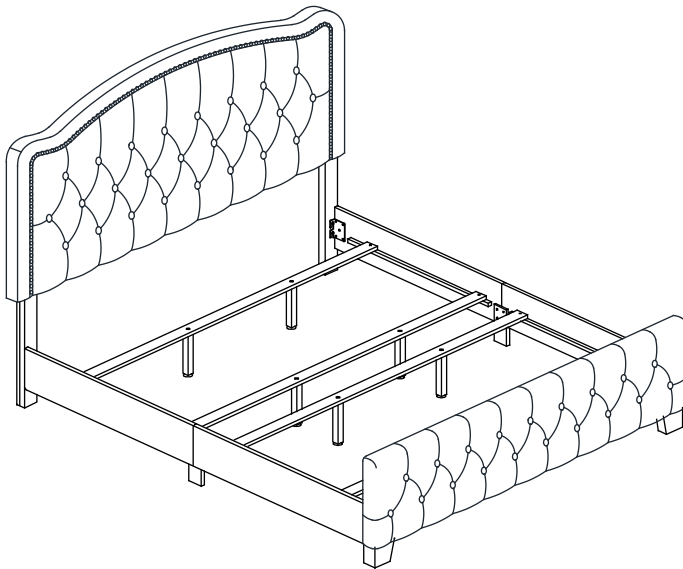

STEP 1

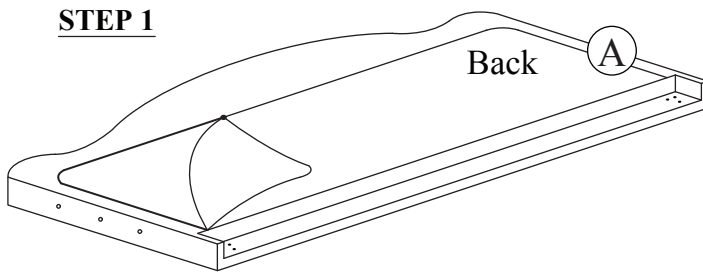

Open the zipper stitched on the back of Headboard (A) and take out the Footboard (D) from the storage space of Headboard (A).

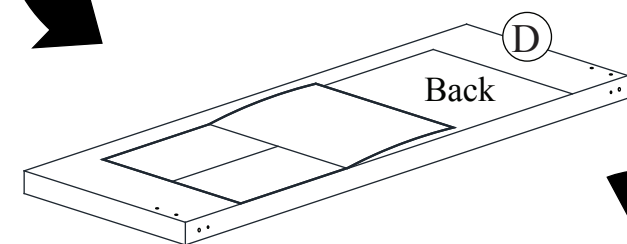

Tear open the Velcro on the back of Footboard (D) and take out the Side Rail (F) & (G) from the storage space of Footboard (D).

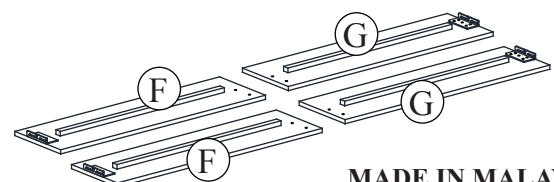

MADE IN MALAYSIA

Thank you for purchasing this quality product. Be sure to check all packing material carefully for small parts that may have come loose inside the carton during shipment.

STEP 2

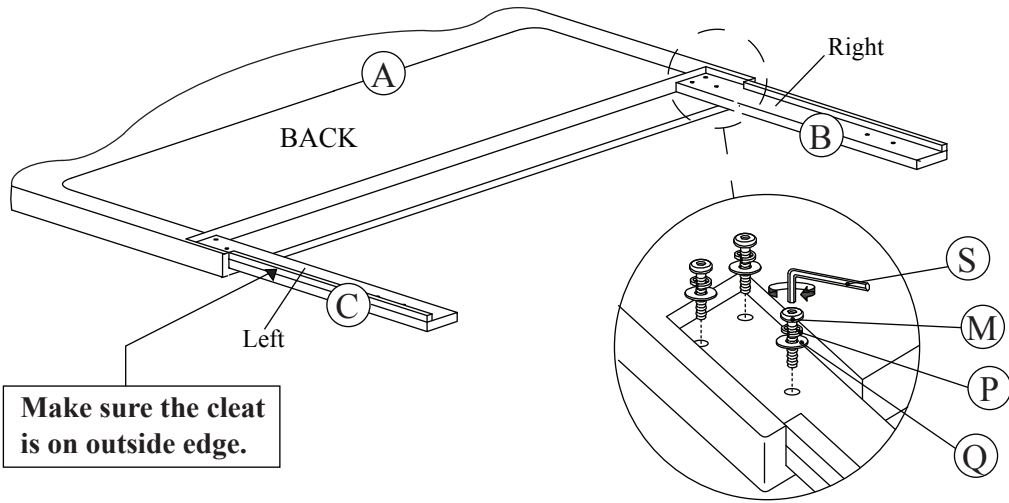

STEP 3

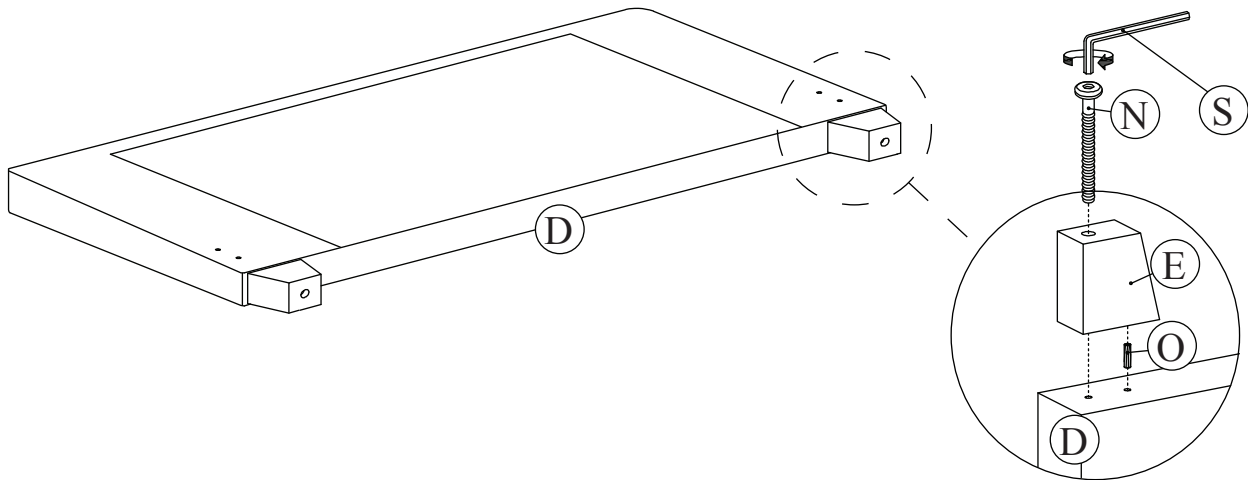

STEP 4

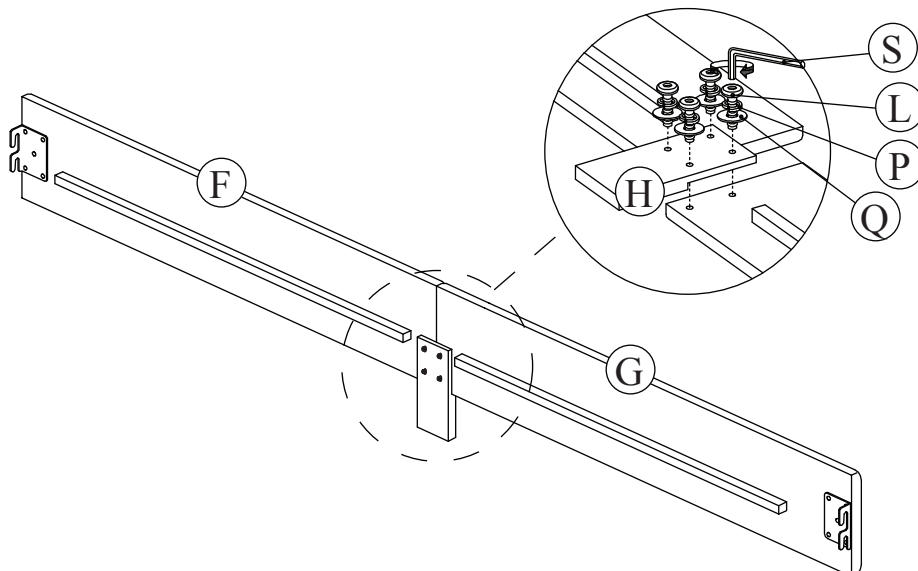

MADE IN MALAYSIA



ASSEMBLY INSTRUCTIONS
ITEM NO:WA-8214-KB
DESCRIPTION:KING UPH
BED-AVERY BLACK VELVET

Thank you for purchasing this quality product. Be sure to check all packing material carefully for small parts that may have come loose inside the carton during shipment.

STEP 5

Note: Don't tighten all bolts until the end of STEP 6.

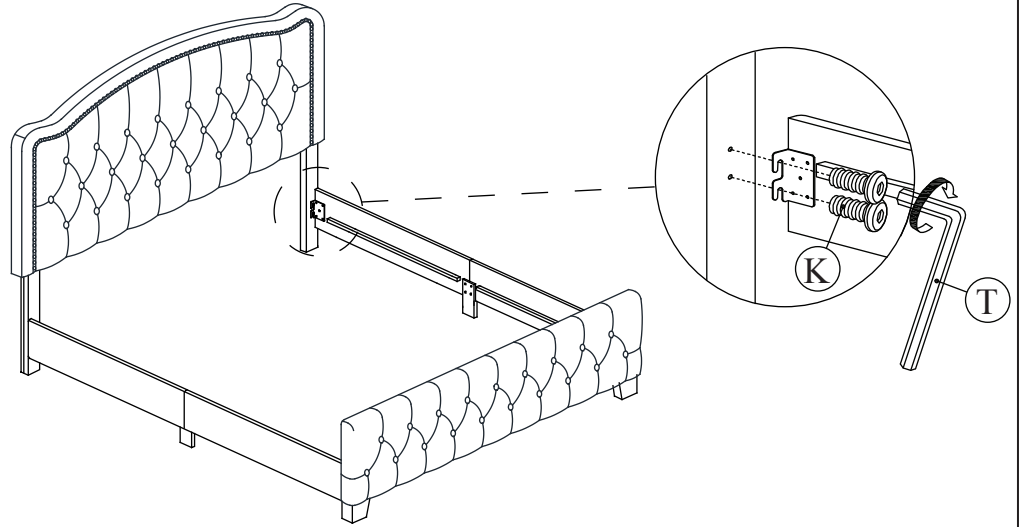

STEP 6

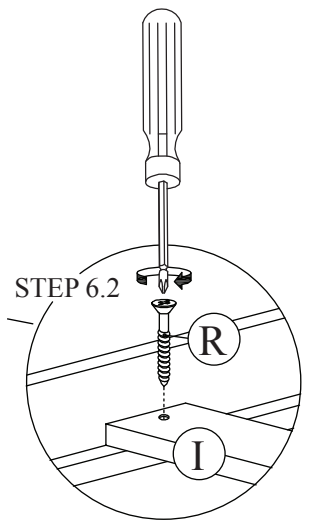
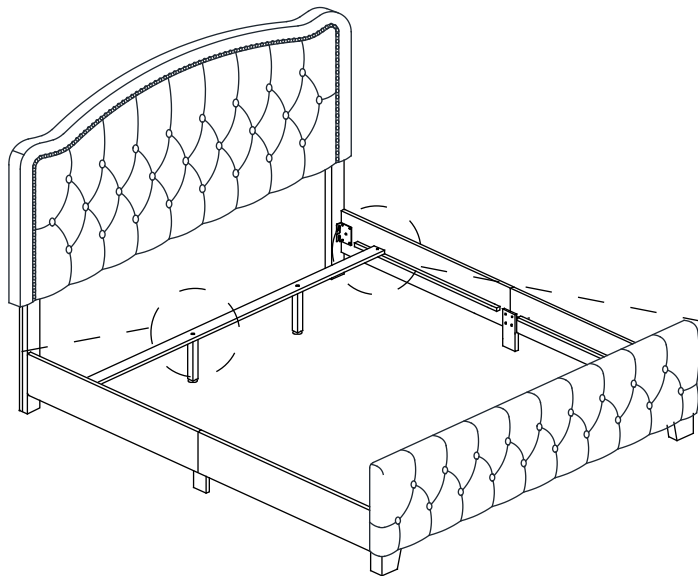
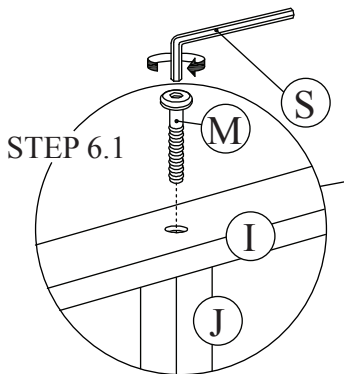

STEP 7

Complete Assembly

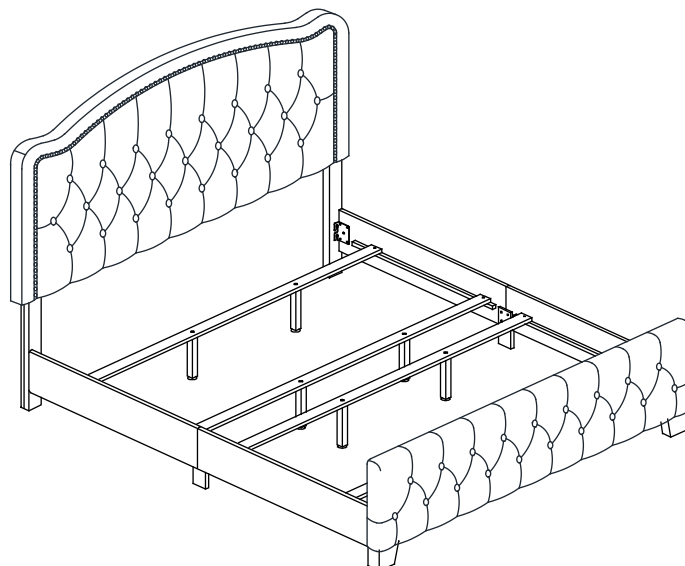

MADE IN MALAYSIA