





# ASSEMBLY INSTRUCTION

ITEM # : 1913-106SHQR QN BKCS HDBD-DAKOTA GRAY

NOTE : THIS ITEM NOT RECOMMENDED FOR COMMERCIAL USE  
KEEP THIS DOCUMENT FOR REFERENCE IN CASE PARTS ARE NEEDED

DO NOT TIGHTEN SCREWS UNTIL COMPLETELY ASSEMBLED !!







## PARTS LIST

NO.		DESCRIPTION	QTY
A		HEADBOARD BOOKCASE	1
B		LEG (R)	1
C		LEG (L)	1
D		FRONT STRETCHER	1
E		REAR STRETCHER	1

## TOOLS REQUIRED (NOT PROVIDED)

PHILIP SCREW DRIVER	1 PC
---------------------	------

## HARDWARE LIST

NO.		DESCRIPTION		QTY
1		BOLT	M6 x 35	12
2		SPRING WASHER	M6	12
3		FLAT WASHER	M6 x 19	12
4		ALLEN KEY	M4	1
5		PANHEAD	M4 x 32	4
6		STRAIGHT ALLEN KEY	M4	1

### STEP 1

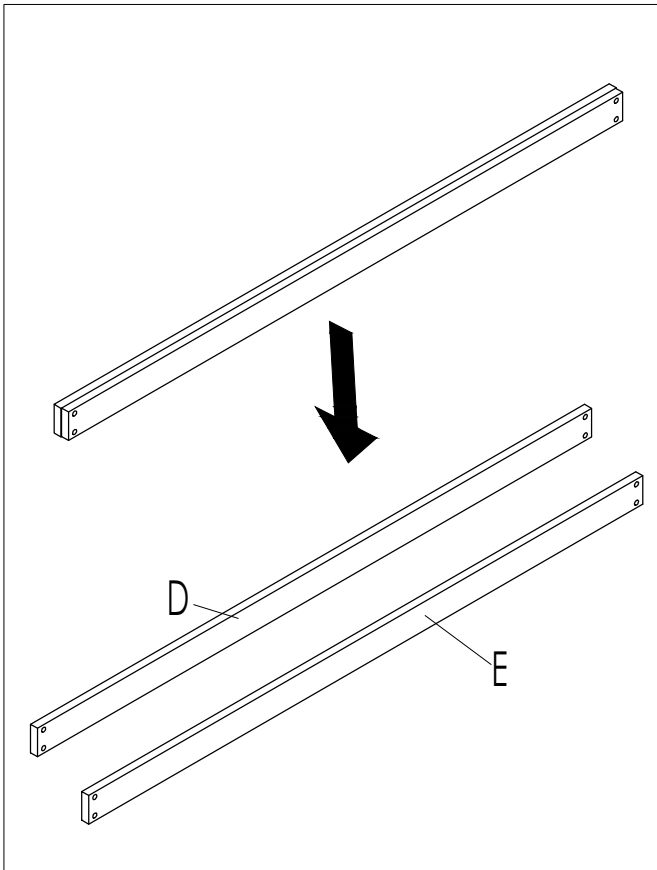

### STEP 2

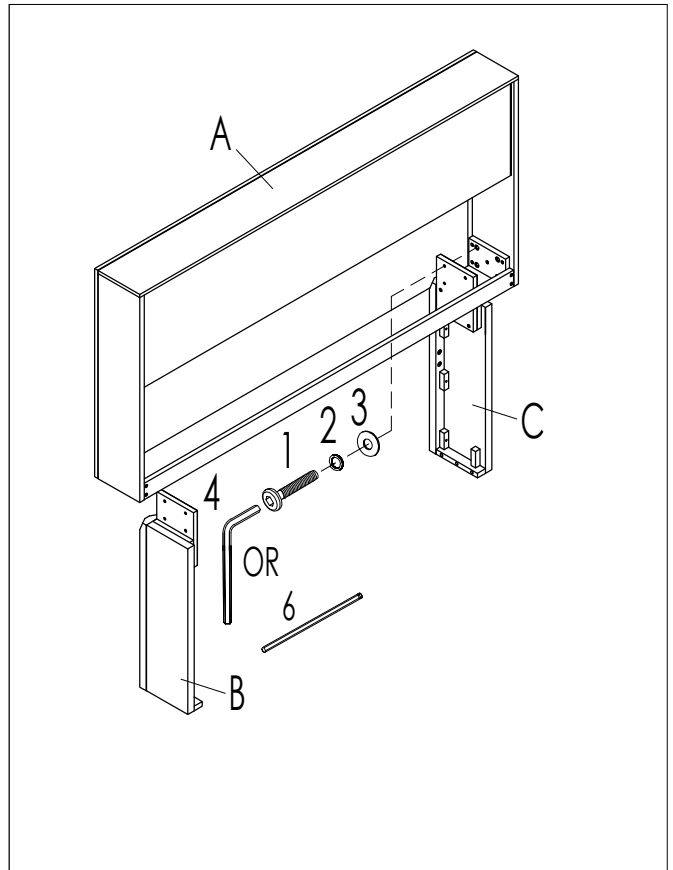



# ASSEMBLY INSTRUCTION

ITEM # : 1913-106SHQR QN BKCS HBDB-DAKOTA GRAY

NOTE : THIS ITEM NOT RECOMMENDED FOR COMMERCIAL USE  
KEEP THIS DOCUMENT FOR REFERENCE IN CASE PARTS ARE NEEDED

DO NOT TIGHTEN SCREWS UNTIL COMPLETELY ASSEMBLED !!

STEP 3

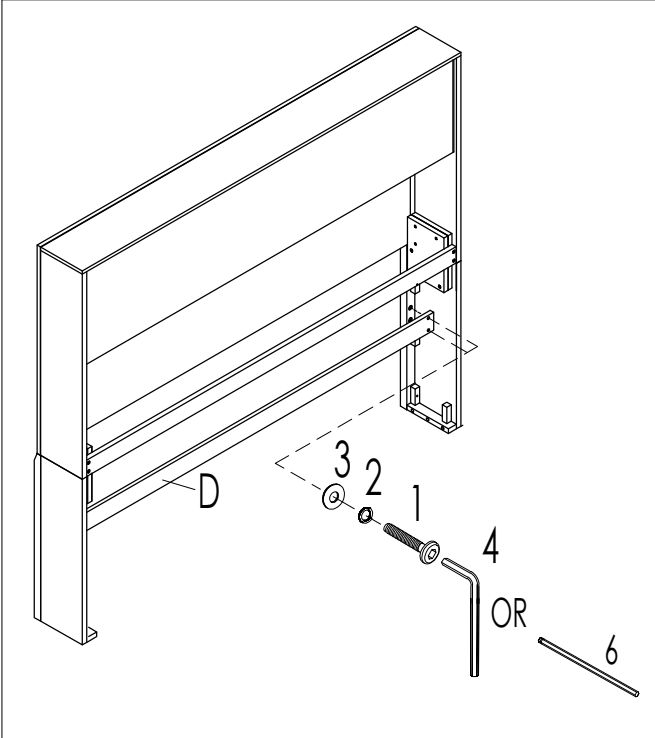

STEP 4

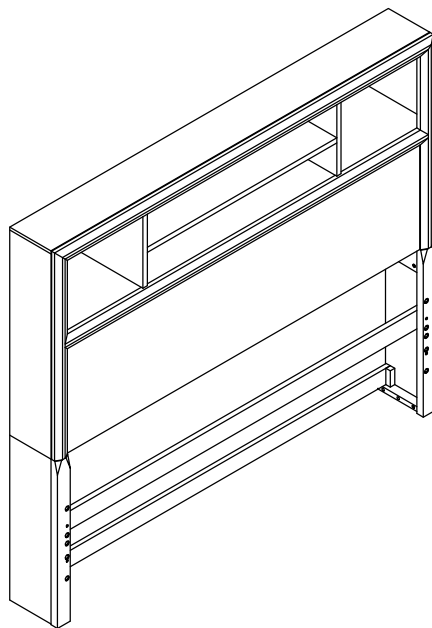
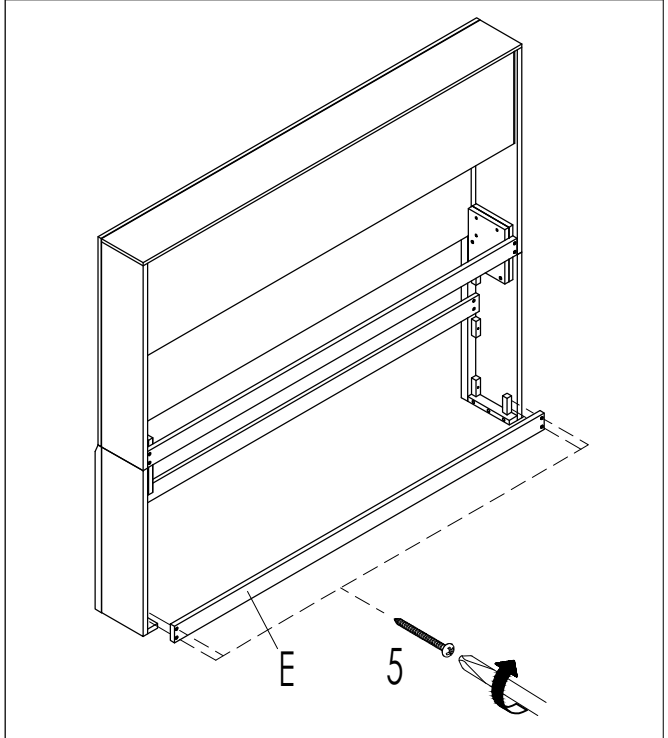



# ASSEMBLY INSTRUCTION

ITEM # : 1913-106SHQR QN BKCS HBDB-DAKOTA GRAY  
 ITEM # : 1913-106SFQR QN STG FTBD & SLTS-DAKOTA GRAY  
 ITEM # : 1913-106DRWR 1 SD DRW+1 FTBD DRW-DAKOTA GRAY  
 ITEM # : 1913-106RLR QN/KG STRG RAILS-DAKOTA GRAY

**NOTE : THIS ITEM NOT RECOMMENDED FOR COMMERCIAL USE  
 KEEP THIS DOCUMENT FOR REFERENCE IN CASE PARTS ARE NEEDED**

**DO NOT TIGHTEN SCREWS UNTIL COMPLETELY ASSEMBLED !!**

PARTS LIST			
NO.		DESCRIPTION	QTY
A		HEADBOARD	1
B		FOOTBOARD	1
C		SIDE RAIL	2
D		FOOTBOARD DRAWER BASE FRAME	1
E		SLAT ROLL (1540 x 42 x 17mm)	1
F		VERTICAL LEG - 1 (447 x 29 x 29mm)	6
G		VERTICAL LEG - 2 (356 x 29 x 29mm)	2
H		VERTICAL LEG - 3 (339 x 29 x 29mm)	2
I		VERTICAL LEG - 4 (112 x 29 x 29mm)	6
J		SIDE RAIL DRAWER BASE FRAME	2
K		CTR. SUPPORT	2
L		FOOTBOARD DRAWER	2
M		SIDE RAIL DRAWER	2

TOOLS REQUIRED (NOT PROVIDED)	
PHILIP SCREW DRIVER	1 PC

HARDWARE LIST				
NO.		DESCRIPTION		QTY
1		BOLT	M6 x 35	20
2		SPRING WASHER	M6	24
3		FLAT WASHER	M6 x 19	20
4		FLAT WASHER	M6 x 13	4
5		ALLEN KEY	M4	1
6		BOLT	M6 x 45	4
7		PANHEAD	M4 x 32	26
8		WOOD DOWEL	Ø8 x 30	11
9		STRAIGHT ALLEN KEY	M4	1

## STEP 1

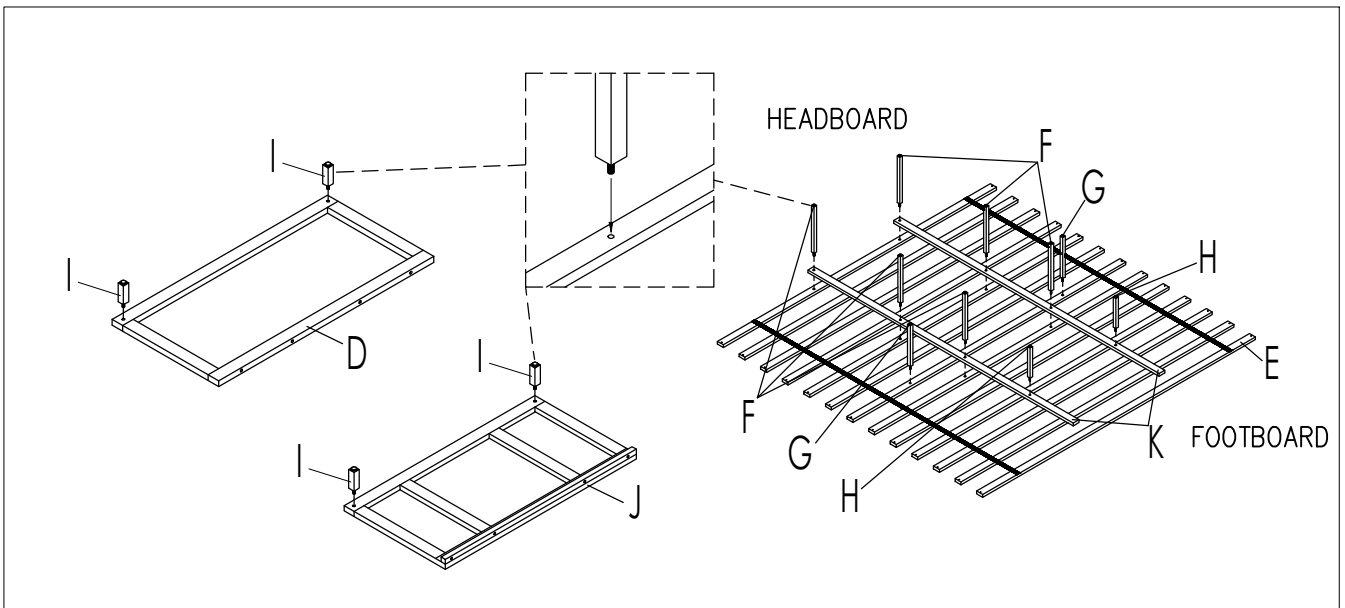





# ASSEMBLY INSTRUCTION

ITEM # : 1913-106SHQR QN BKCS HDBD-DAKOTA GRAY

NOTE : THIS ITEM NOT RECOMMENDED FOR COMMERCIAL USE  
KEEP THIS DOCUMENT FOR REFERENCE IN CASE PARTS ARE NEEDED

DO NOT TIGHTEN SCREWS UNTIL COMPLETELY ASSEMBLED !!







## PARTS LIST

NO.		DESCRIPTION	QTY
A		HEADBOARD BOOKCASE	1
B		LEG (R)	1
C		LEG (L)	1
D		FRONT STRETCHER	1
E		REAR STRETCHER	1

## TOOLS REQUIRED (NOT PROVIDED)

PHILIP SCREW DRIVER	1 PC
---------------------	------

## HARDWARE LIST

NO.		DESCRIPTION		QTY
1		BOLT	M6 x 35	12
2		SPRING WASHER	M6	12
3		FLAT WASHER	M6 x 19	12
4		ALLEN KEY	M4	1
5		PANHEAD	M4 x 32	4
6		STRAIGHT ALLEN KEY	M4	1

### STEP 1

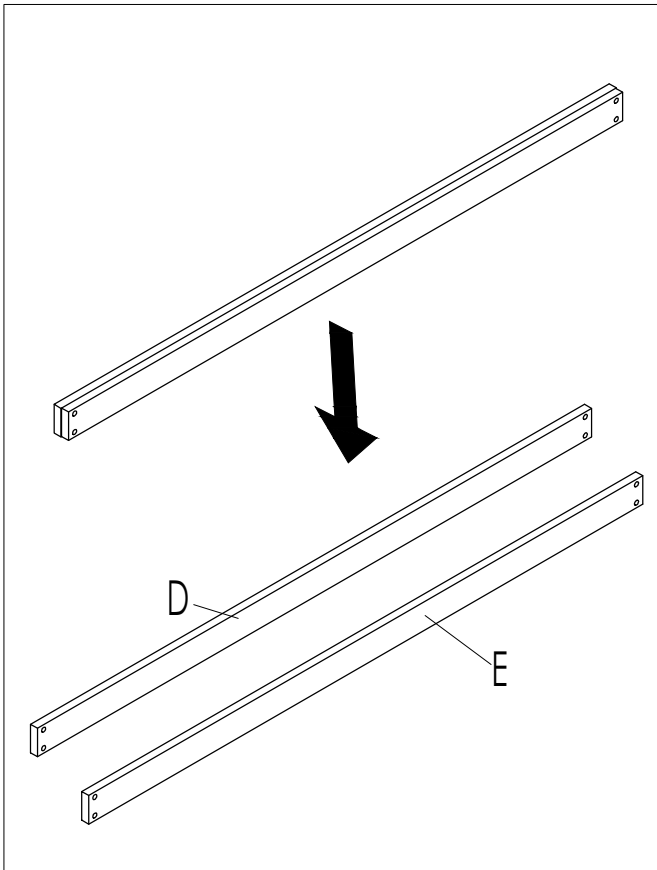

### STEP 2

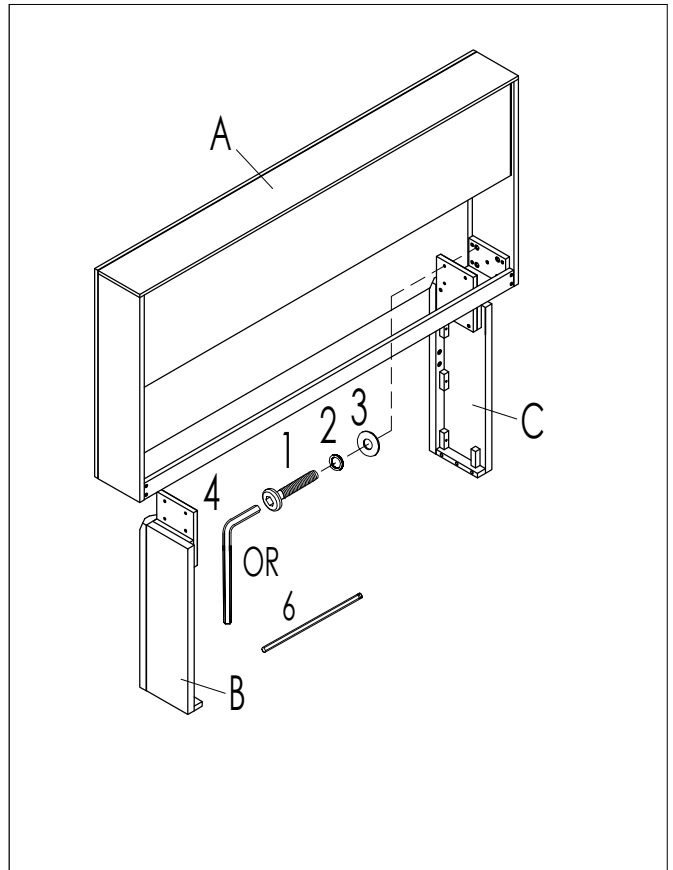



# ASSEMBLY INSTRUCTION

ITEM # : 1913-106SHQR QN BKCS HBDB-DAKOTA GRAY  
 ITEM # : 1913-106SFQR QN STG FTBD & SLTS-DAKOTA GRAY  
 ITEM # : 1913-106DRWR 1 SD DRW+1 FTBD DRW-DAKOTA GRAY  
 ITEM # : 1913-106RLR QN/KG STRG RAILS-DAKOTA GRAY

NOTE : THIS ITEM NOT RECOMMENDED FOR COMMERCIAL USE  
 KEEP THIS DOCUMENT FOR REFERENCE IN CASE PARTS ARE NEEDED

DO NOT TIGHTEN SCREWS UNTIL COMPLETELY ASSEMBLED !!

## STEP 2

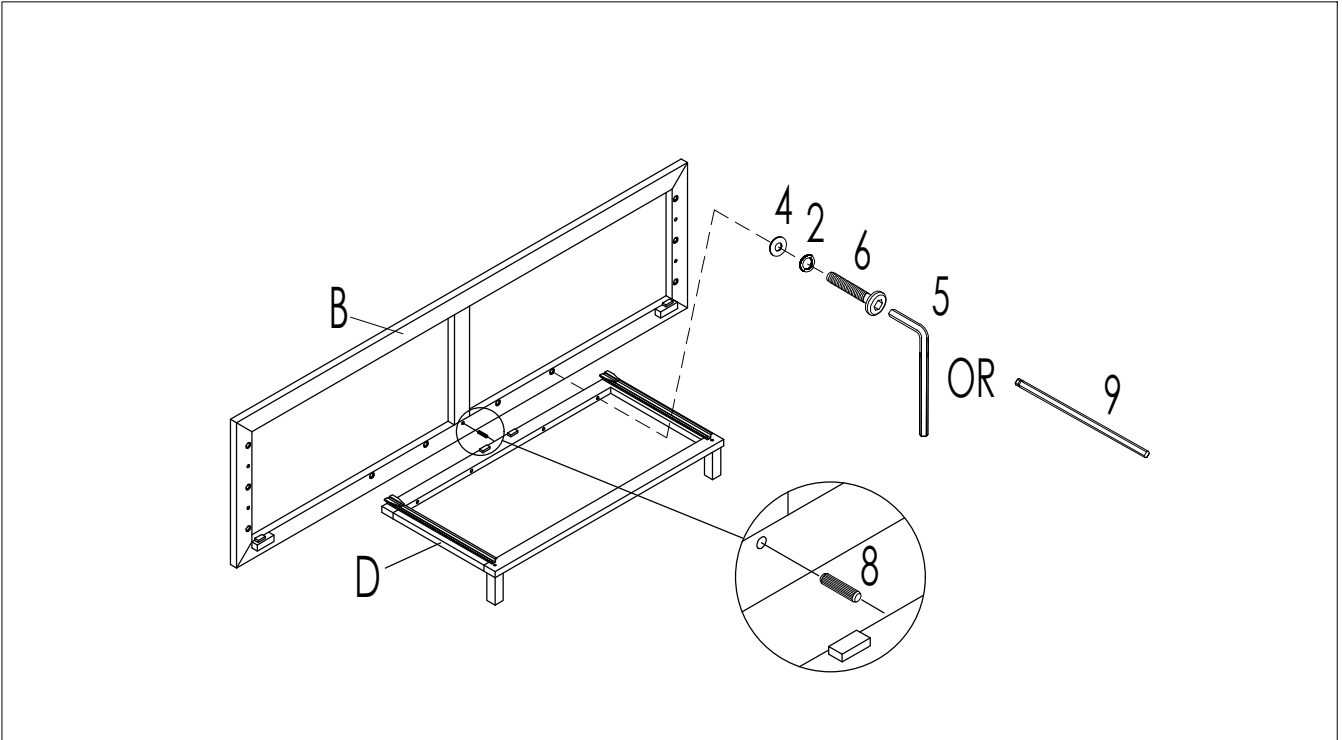

## STEP 3

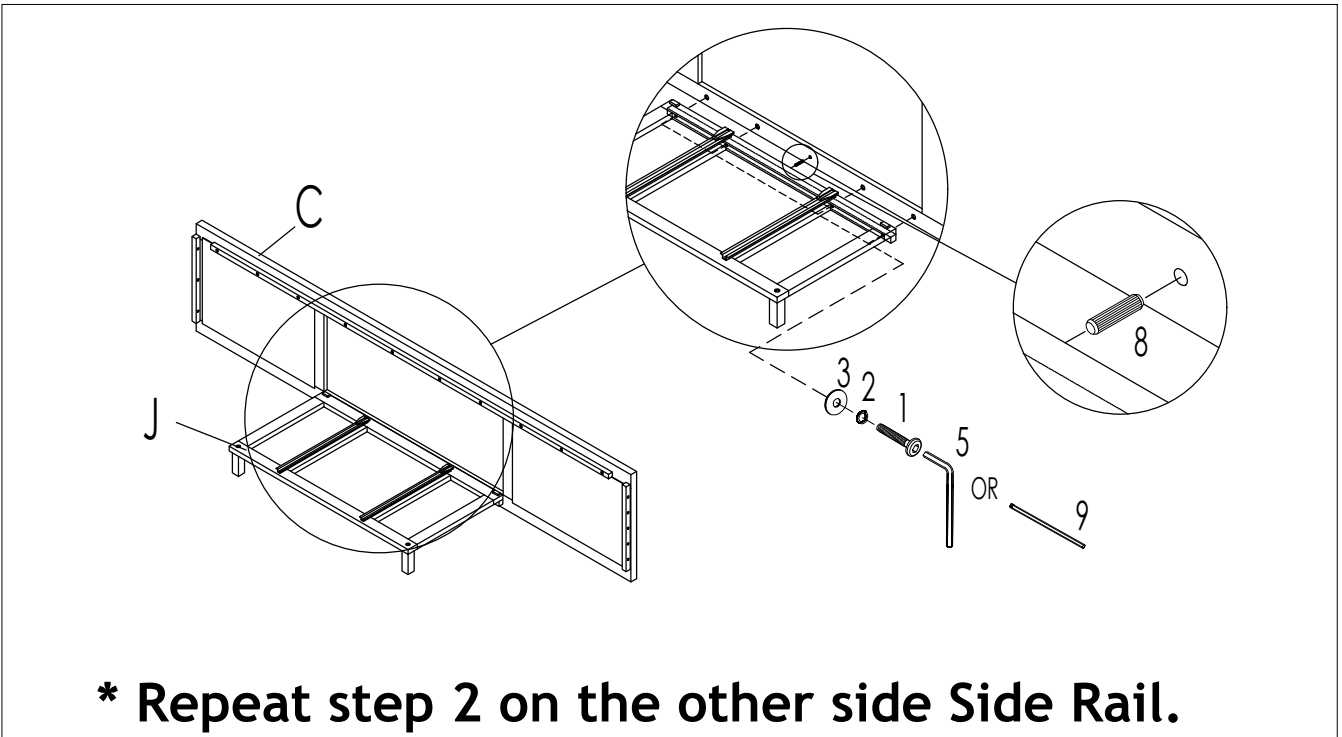

**\* Repeat step 2 on the other side Side Rail.**

AMERICAN SIGNATURE, INC.

VCF



# ASSEMBLY INSTRUCTION

ITEM # : 1913-106SHQR QN BKCS HBDB-DAKOTA GRAY  
ITEM # : 1913-106SFQR QN STG FTBD & SLTS-DAKOTA GRAY  
ITEM # : 1913-106DRWR 1 SD DRW+1 FTBD DRW-DAKOTA GRAY  
ITEM # : 1913-106RLR QN/KG STRG RAILS-DAKOTA GRAY

NOTE : THIS ITEM NOT RECOMMENDED FOR COMMERCIAL USE  
KEEP THIS DOCUMENT FOR REFERENCE IN CASE PARTS ARE NEEDED

DO NOT TIGHTEN SCREWS UNTIL COMPLETELY ASSEMBLED !!

## STEP 4

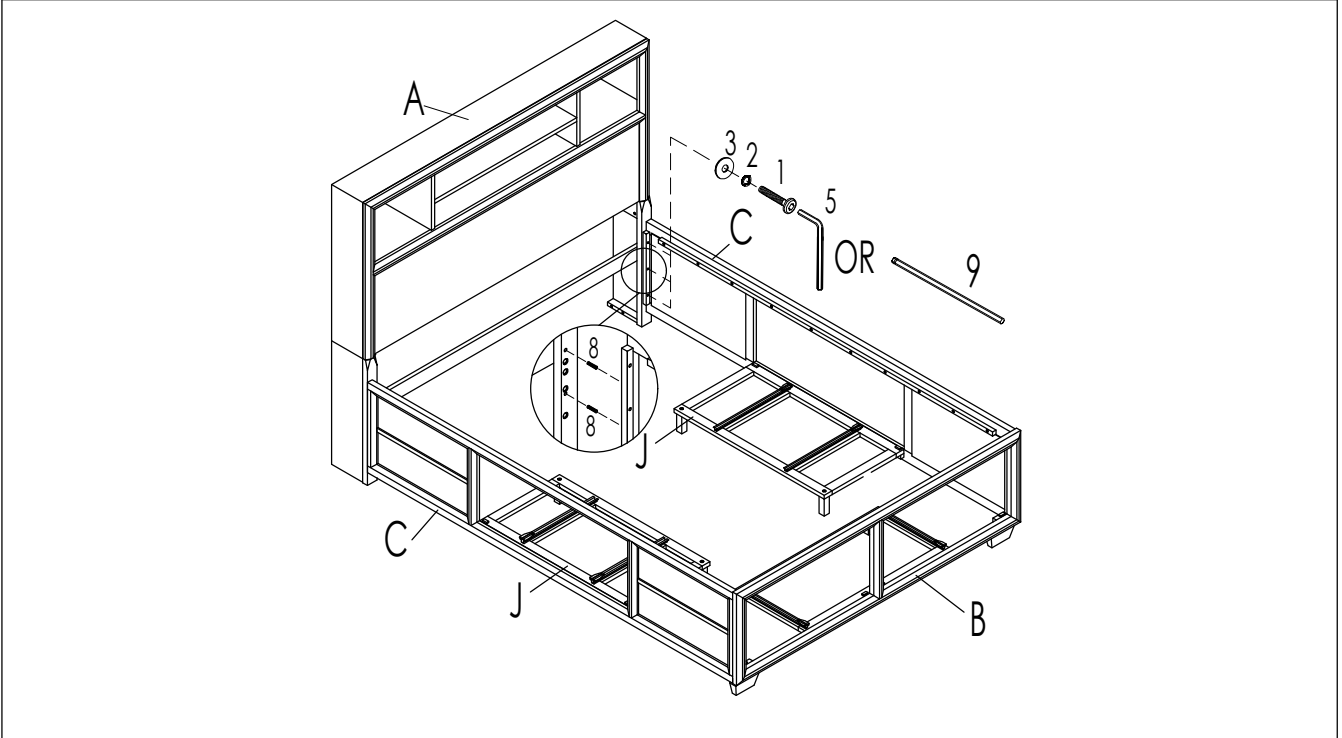

## STEP 5

