

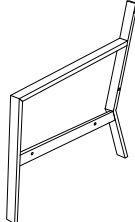

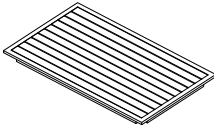

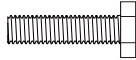

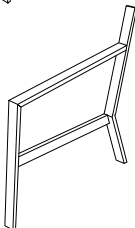

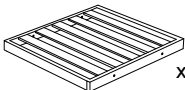

PARTS LIST / LISTE DES PIÈCES / LISTA DE PIEZAS

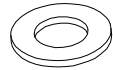
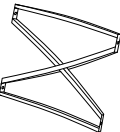
ITEM NO. / ARTICLE NO. / ARTICULO NO : DS-D321

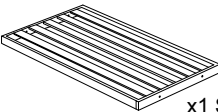
DESCRIPTION / DESCRIPCIÓN : X Back Outdoor Set / X Back Outdoor Set / Set de espalda al aire libre X

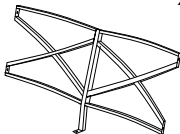
	A x3 Left Arm Panel x3 Panneau du bras gauche x3 Panel del brazo izquierdo		G x1 Table Panel x1 Panneau de table x1 Panel de mesa		M x8(Extra 1) M8*40mm Bolt x8(Extra 1) Boulon M8*40mm x8(Extra 1) Perno M8*40mm
	B x3 Right Arm Panel x3 Panneau de bras droit x3 Panel del brazo derecho		H x4 Table Leg x4 Pied de table x4 Pata de la mesa		N x25(Extra 1) M6 Washer x25(Extra 1) Rondelle M6 x25(Extra 1) Lavadora M6
	C x2 Chair Seat Panel x2 Panneau de siège de chaise x2 Panel del asiento de la silla		I x4 Seat Cushion x4 Coussin de siege x4 Cojín del asiento		O x8(Extra 1) M8 Washer x8(Extra 1) Rondelle M8 x8(Extra 1) Lavadora M8
	D x2 Chair Back Panel x2 Panneau arrière de la chaise x2 Panel trasero de la silla		J x4 Back Cushion x4 coussin de dos x4 Amortiguador trasero		P x1 M8 Wrench x1 Clé M8 x1 Llave M8
	E x1 Sofa Seat Panel x1 Panneau de siège de canapé x1 Panel del asiento del sofá		K x13 M6*15mm Bolt x13 Boulon M6*15mm x13 Perno M6*15mm		Q x1 M6 Allen Wrench x1 Clé allen m6 x1 Llave allen M6
	F x1 Sofa Back Panel x1 Panneau arrière du canapé x1 Sofá panel trasero		L x12(Extra 1) M6*25mm Bolt x12(Extra 1) Boulon M6*25mm x12(Extra 1) Perno M6*25mm		

ASSEMBLY INSTRUCTIONS / NOTICE DE MONTAGE / INSTRUCCIONES DE MONTAJE

ITEM NO. / ARTICLE NO. / ARTICULO NO : DS-D321

DESCRIPTION / DESCRIPCIÓN : X Back Outdoor Set / X Back Outdoor Set / Set de espalda al aire libre X

Steps 1-2

Chair Assembly:

Lay Left Arm Panel (A) on it's side on a soft dry surface. Add chair Seat Panel (C) aligning the bolt holes with those on the left arm panel. Add Washer (N) to 25mm length Bolt (L). Use provided Allen Wrench (Q) to tighten, but do not tighten completely. Now add Right Arm Panel (B) aligning the bolt holes and repeat the bolt tightening process. Make sure the arm and seat panels are aligned and tighten bolts completely.

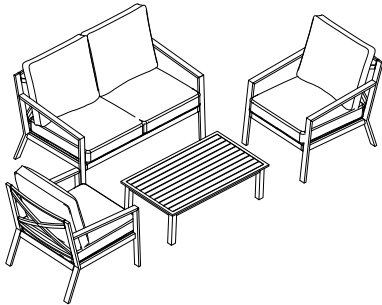

Step1

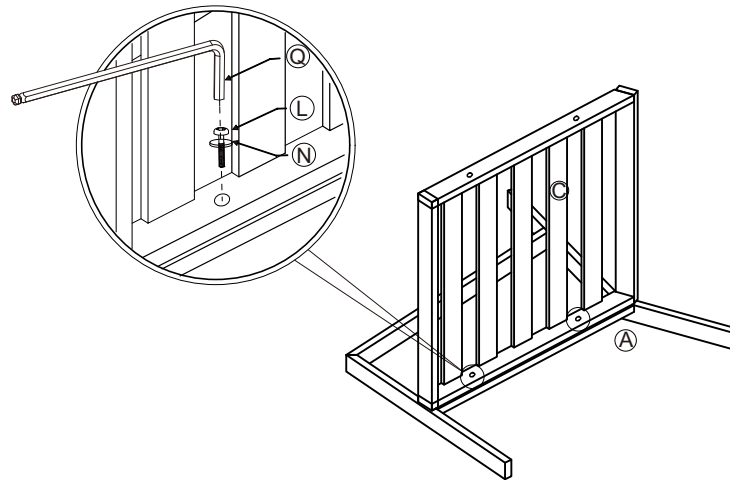

Step2

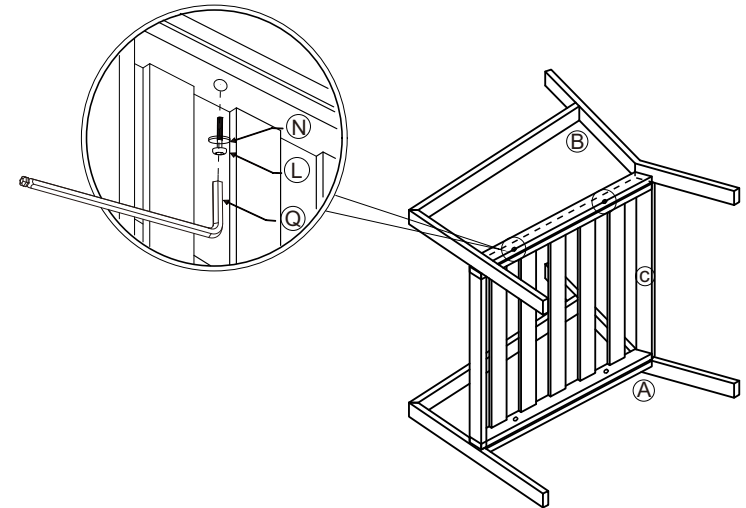

Step3

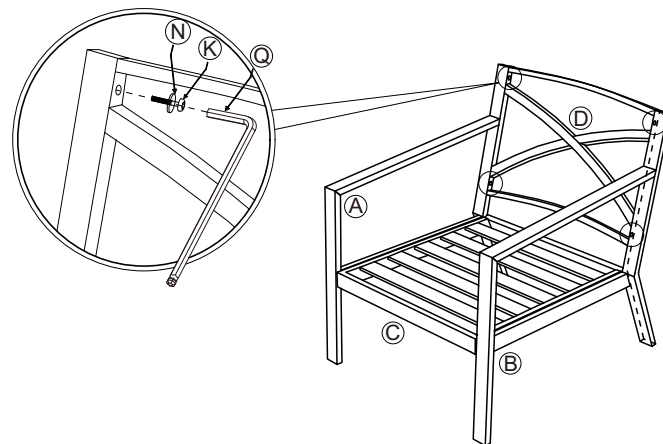

Step 3

Chair Assembly Continued:

Add the Back Panel (D) to the assembled parts (A,B&C) aligning the bolt holes. Add Small Washer (N) to 15mm length Short Bolt (K). Insert into the bolt holes as shown in the diagram and use the provided Allen Wrench (Q) to tighten, but do not tighten completely. Once all four bolts have been added, make sure the back is aligned with the arm panels and tighten bolts completely.

ASSEMBLY INSTRUCTIONS / NOTICE DE MONTAGE / INSTRUCCIONES DE MONTAJE

ITEM NO. / ARTICLE NO. / ARTICULO NO : DS-D321

DESCRIPTION / DESCRIPCIÓN : X Back Outdoor Set / X Back Outdoor Set / Set de espalda al aire libre X

Steps 4-5

Sofa Assembly:

Lay Left Arm Panel (A) on it's side on a soft dry surface. Add Sofa Seat Panel (E) aligning the bolt holes with those on the left arm panel. Add Washer (N) to 25mm length Bolt (L). Use provided Allen Wrench (Q) to tighten, but do not tighten completely. Now add Right Arm Panel (B) aligning the bolt holes and repeat the bolt tightening process. Make sure the arm and seat panels are aligned and tighten bolts completely.

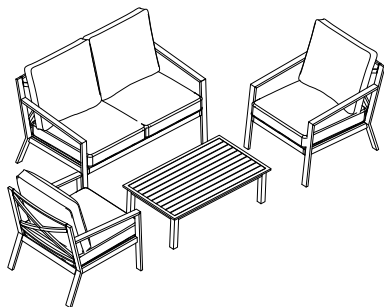

Step4

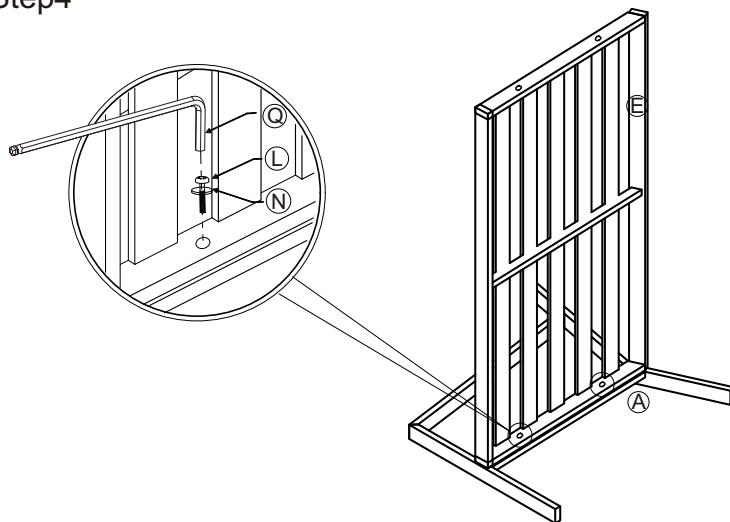

Step5

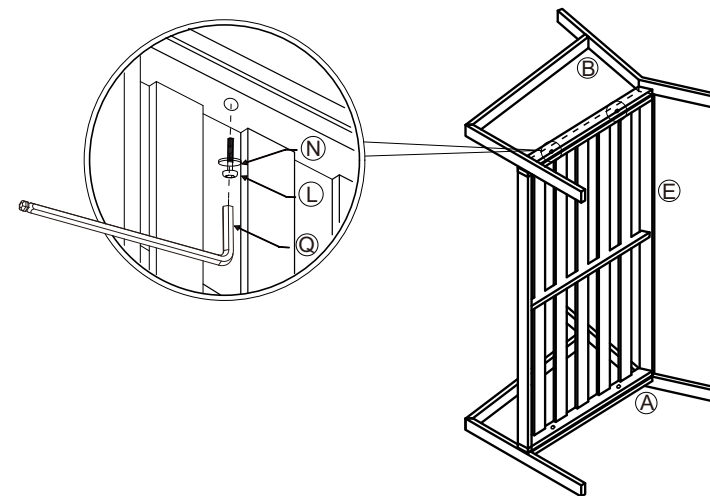

Step6

Step 6

Sofa Assembly Continued:

Add the Back Panel (F) to the assembled parts (A,B&E) aligning the bolt holes. Add Small Washer (N) to 15mm length Short Bolt (K). Insert into the bolt holes as shown in the diagram and use the provided Allen Wrench (Q) to tighten, but do not tighten completely. Once all five bolts have been added, make sure the back is aligned with the arm panels and tighten bolts completely.

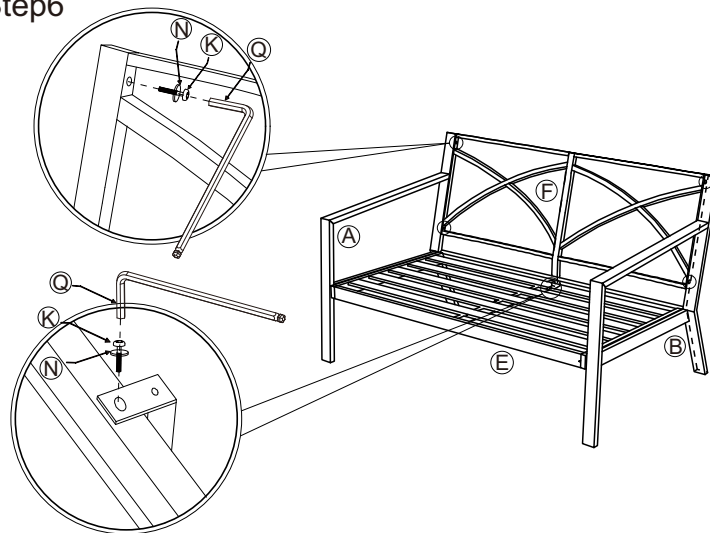

ASSEMBLY INSTRUCTIONS / NOTICE DE MONTAGE / INSTRUCCIONES DE MONTAJE

ITEM NO. / ARTICLE NO. / ARTICULO NO : DS-D321

DESCRIPTION / DESCRIPCIÓN : X Back Outdoor Set / X Back Outdoor Set / Set de espalda al aire libre X

Steps 7

Table Assembly:

Lay Table Panel (G) on a soft dry surface with the bottom facing up. Add Legs (H) aligning the bolt holes. Add Large Washer (O) to Hex Head Bolt (M) and insert into bolt holes and tighten with Wrench (P)

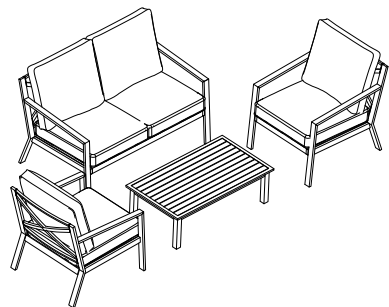

Step 8

Place assembled furniture in the desired area and add Seat Cushions (I) & Back Cushions (J).

Enjoy!

Step7

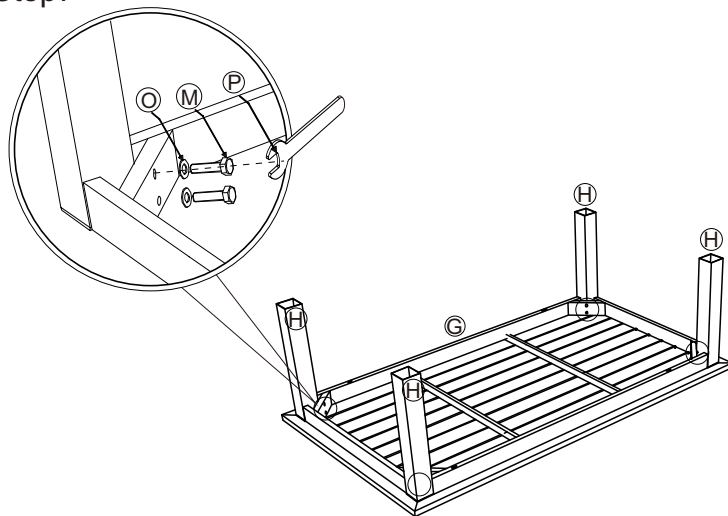

Step8

