



AMERICAN SIGNATURE, INC.

ASSEMBLY INSTRUCTIONS

ITEM NO: OD8255-24 Rnd Dng Tbl - Chart House Charcoal

ITEM NO: OD8305-24 Rnd Dng Tbl - Chart House Gray

ITEM NO: OD8339-24 Rnd Dng Tbl - Chart House Nutmeg





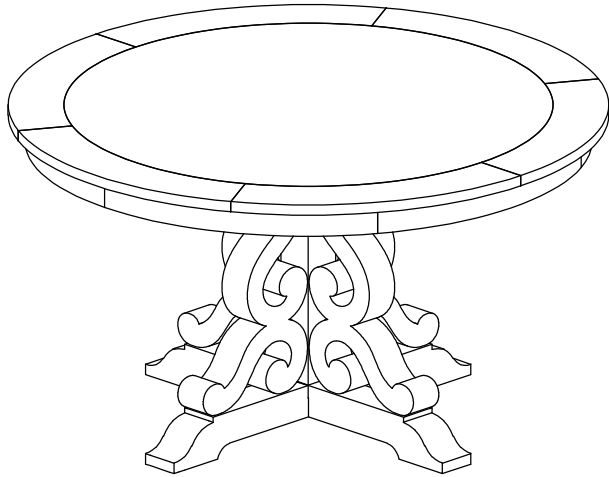

Thank you for purchasing this quality product. Be sure to check all packing material carefully for small parts, that may have come loose inside the carton during shipment.

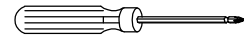





**TOOL REQUIRED (NOT PROVIDED):
PHILLIPS SCREW DRIVER**



HARDWARE LIST

No.	Description			Q'ty
A		Bolt	Φ 5/16" * 50mm	10
		Flat washer	Φ 9/Φ 22mm	
		Lock washer	Φ 9/Φ 11mm	
B		Wrench	12mm	1

PARTS LIST

No.	Description	Picture	Q'ty
1	Table top		1
2	Wood mending plate		1
3	Leg frame		1
4	Fretwork		2
5	Lower base		1

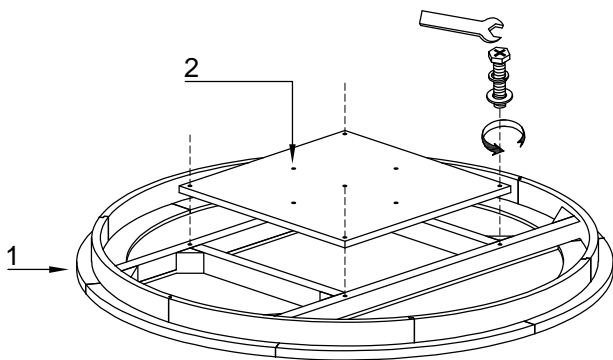

Step 1: Remove wood mending plate as show picture

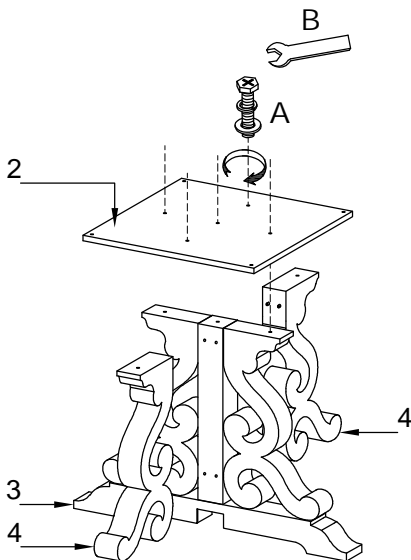

Step 2

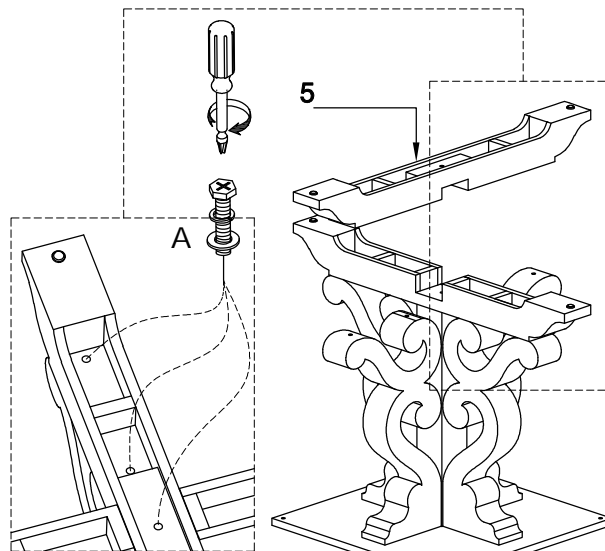

Step 3

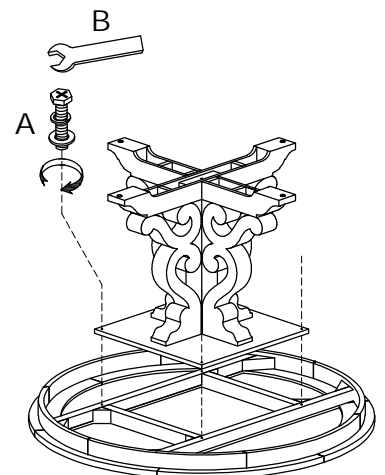

Step 4

MADE IN VIETNAM



AMERICAN SIGNATURE, INC.



ASSEMBLY INSTRUCTIONS

ITEM NO: OD8255-62 *Slat Bk Sd Chr - Chart House Charcoal*

ITEM NO: OD8305-62 *Slat Bk Sd Chr - Chart House Gray*

ITEM NO: OD8339-62 *Slat Bk Sd Chr - Chart House Nutmeg*

Thank you for purchasing this quality product. Be sure to check all packing material carefully for small parts, that may have come loose inside the carton during shipment.

**TOOL REQUIRED (NOT PROVIDED):
PHILLIPS SCREW DRIVER**

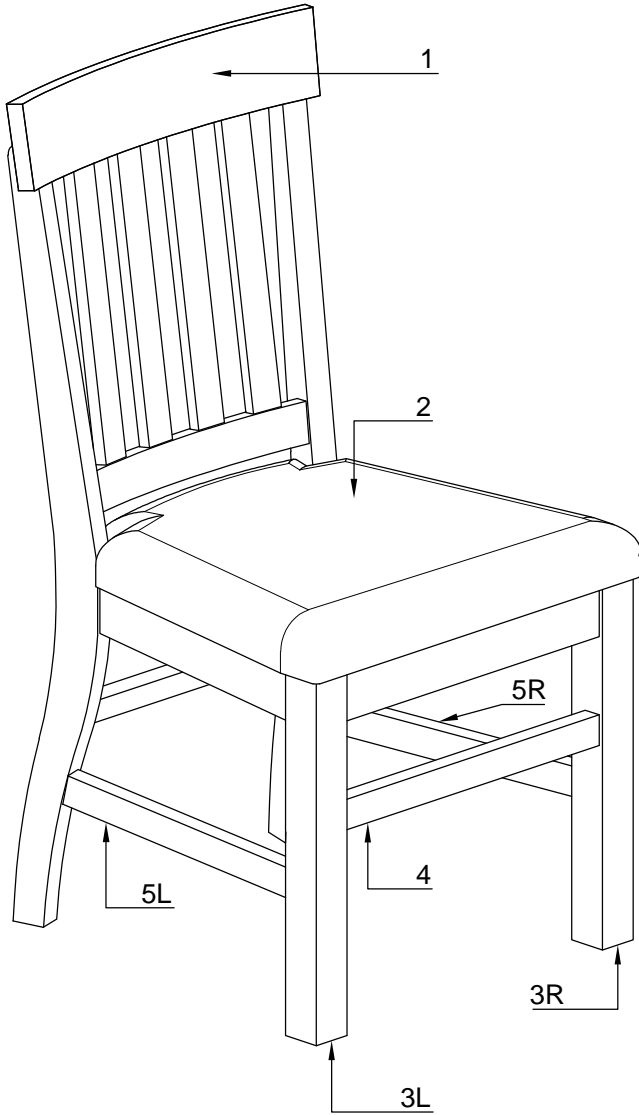

HARDWARE LIST

No.	Description			Q'ty
A		Bolt	Φ 5/16" * 32mm	3
		Flat washer	Φ 9/Φ 22mm	
		Lock washer	Φ 9/Φ 11mm	
B		Bolt	Φ 5/16" * 70mm	4
		Flat washer	Φ 9/Φ 22mm	
		Lock washer	Φ 9/Φ 11mm	
C		Flat washer	Φ 9/Φ 22mm	4
D		Lock washer	Φ 9/Φ 11mm	4
E		Nut	5/16"	4
F		Wrench	12mm	1
G		Screw	Φ 4 * 40	6

PARTS LIST

No.	Description	Picture	Q'ty
1	Chair back		1
2	Seat frame		1
3	Left & Right legs		2
4	Front stretcher		1
5	Left & Right stretchers		2

Step 1

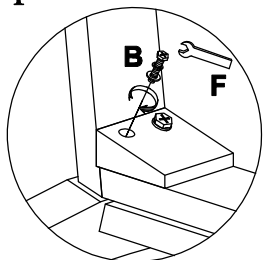

Step 2

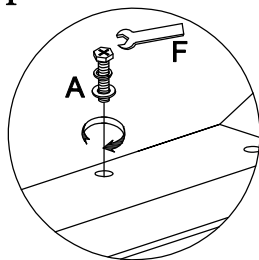

Step 3

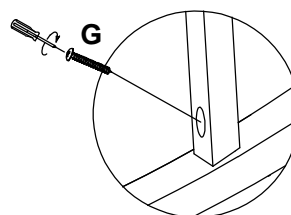

Step 4

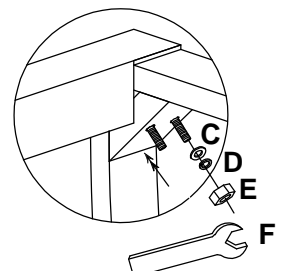

MADE IN VIETNAM