

ASSEMBLY INSTRUCTIONS

Item No: 23306

Description: END TABLE-UNION CITY

Thank you for purchasing this quality product. Be sure to check all packing material carefully for small parts that may have come loose inside the carton during shipment.

Step 1: Place the Table Top (A) upside down on a soft non-abrasive surface and remove the drawers.

Step 2: Attach the Legs (C) to the underneath side of the Table Top with the 1-1/4" long Bolts (D), Spring Washers (F) and Flat Washers (G).

Step 3: Attach the Shelf (B) to the bottom of the Legs with the dowel(J), the 1-1/2" long Bolts (E) and Washers as in previous step. Adjust parts for fit to each other if necessary and tighten all Bolts with the Allen Wrench (H or I).

Step 4: Carefully set the assembled Table upright and reinstall the drawer.

PARTS LIST:

No.	Description	Sketch	Quantity
A	Table Top		1 pc
B	Shelf		1 pc
C	Leg		4 pcs

HARDWARE LIST:

No.	Description	Sketch	Size	Quantity
D	Allen Head Bolt		M5/16" x-1-1/4"	8pcs
E	Allen Head Bolt		M5/16" x 1-1/2"	8pcs
F	Spring Washer		5/16"	16pcs
G	Flat Washer		5/16"	16pcs
H	Allen Wrench		5mm	1pc
I	Straight Allen Wrench		5mm	1pc
J	Dowel		M10x30mm	4pcs

Note: If the straight Wrench (I) is used in a power drill, use care to not overtighten Bolts and possibly damage parts.

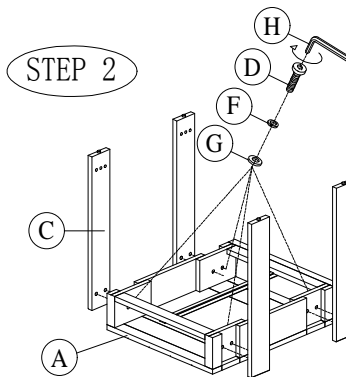
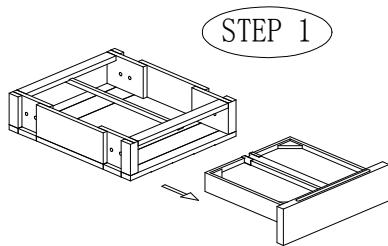

Note: Do not fully install or tighten Bolts until after Shelf is assembled.

