

ASSEMBLY INSTRUCTIONS

ITEM NO.: 3650&3651-36
NIGHT STAND-TRIBECA YTH

THANK YOU FOR PURCHASING THIS QUALITY PRODUCT. BE SURE TO CHECK ALL PACKING MATERIAL CAREFULLY FOR SMALL PARTS THAT MAY HAVE COME LOOSE INSIDE THE CARTON DURING SHIPMENT.

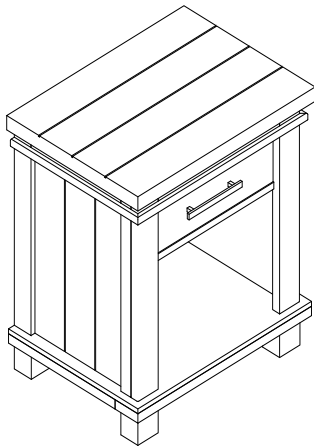
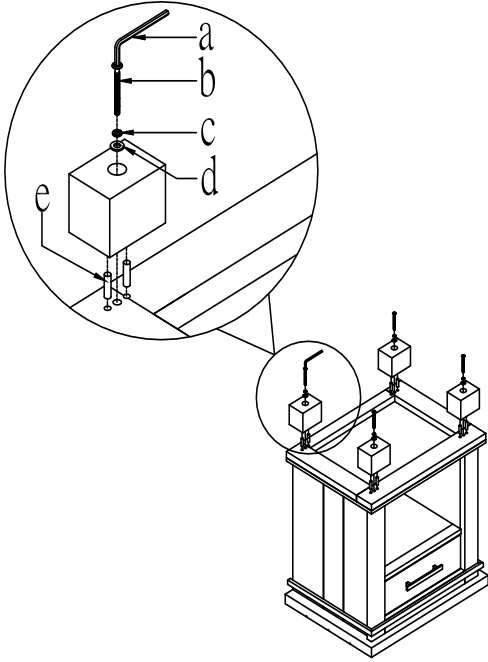

TOOLS REQUIRED (NOT PROVIDED)

PHILLIPS SCREWDRIVER



PARTS LIST:

| NO | DESCRIPTION | SKETCH | QTY |
|----|-------------|--------|-------|
| A | NIGHT STAND | | 1 PC |
| B | BUN FEET | | 4 PCS |

HARDWARE LIST:

| NO | DESCRIPTION | SKETCH | SIZE | QTY |
|----|--------------------|--------|-----------------------|-------|
| a | Allen Key | | 4 x 74 x 29mm | 1 PC |
| b | Bolt | | ϕ 1/4" x 15 x 70mm | 4 PCS |
| c | Spring Washer | | ϕ 1/4" x ϕ 11 x 2mm T | 4 PCS |
| d | Flat Washer | | ϕ 1/4" x ϕ 18 x 2mm T | 4 PCS |
| e | WOODEN DOWEL | | 10*30mm | 8 PCS |
| f | STRAIGHT ALLEN KEY | | 4*100mm | 1PC |
| g | TIPPING RESTRAINT | | | 1 set |

STEP 1: Lay the night stand (A) up side down on a soft surface. Insert wooden dowel (e) to the bottom of night stand (A). Attach bun feet (B) by using allen key (a), bolt (b), spring washer (c), flat washer (d).

Important note:

1. The furniture tipping restraint is stapled to the back of the NIGHT STAND.
2. The hardware bag is packed with NIGHT STAND.