

ASSEMBLY INSTRUCTIONS

ITEM NO.: 3650&3651-20H/47USF/18R
 FL PLANK HB W/STORAGE FOOTBOARD & RAILS -
 TRIBECA YTH

Thank you for purchasing this quality product. Be sure to check all packing material carefully for small parts that may have come loose inside the carton during shipment.

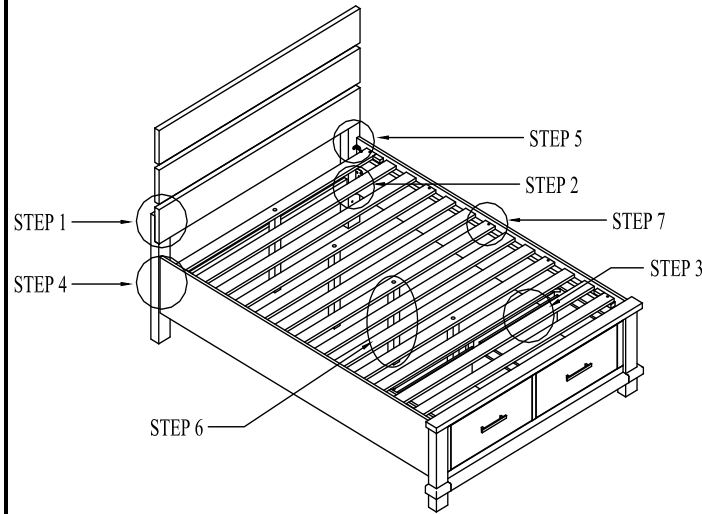

TOOLS REQUIRED (NOT PROVIDED):
 PHILLIPS SCREWDRIVER

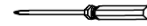

PARTS LIST			
NO.	DESC	SKETCH	Q'TY
A	HEADBOARD		1 PC
B	STORAGE FOOTBOARD		1 PC
C	BED SIDE RAILS		2 PCS
D	CROSS BAR		1 PC
E	SLATS ROLL		1 SET
F	HEADBOARD POST (L + R)		2 PCS
G	CONNECT PANEL		2 PCS
H	SHORT SUPPORT LEG		2 PCS
I	LONG SUPPORT LEG		4 PCS

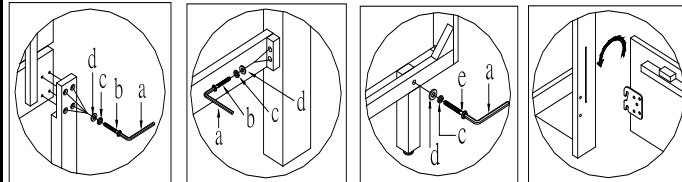

STEP 1

STEP 2

STEP 3

STEP 4

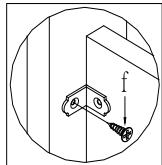

STEP 5

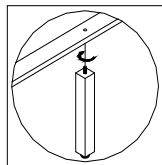

STEP 6

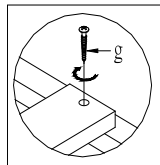

STEP 7

HARDWARE LIST FOR HEADBOARD

NO.	DESCRIPTION	SKETCH	SIZE	Q'TY
a	Allen Key		4 x 74 x 29mm	1 PC
b	Bolt		ϕ 1/4" x 15 x 45mm	12 PCS
c	Spring Washer		ϕ1/4" x ϕ11 x 2mm T	12 PCS
d	Flat Washer		ϕ1/4" x ϕ18 x 2mm T	12 PCS
g	Straight Allen Key		4*100mm	1 PC

HARDWARE LIST FOR FOOTBOARD

NO.	DESCRIPTION	SKETCH	SIZE	Q'TY
a	Allen Key		4 x 74 x 29mm	1 PC
e	Bolt		ϕ 1/4" x 15 x 38mm	2 PCS
c	Spring Washer		ϕ1/4" x ϕ11 x 2mm T	2 PCS
d	Flat Washer		ϕ1/4" x ϕ18 x 2mm T	2 PCS
g	Screw		#8 x 30mm	10 PCS
f	Screw		#6 x 15mm	4 PC
h	Straight Allen Key		4x100mm	1 PC

- STEP 1: ATTACH HEADBOARD POST (F) HEADBOARD (A) BY USING ALLEN KEY (a), BOLT (b), SPRING WASHER (c) AND FLAT WASHER (d).
 STEP 2: ATTACH CROSS BAR (D) TO THE HEADBOARD POST (F) BY USING ALLEN KEY (a), BOLT (b), SPRING WASHER (c) AND FLAT WASHER (d).
 STEP 3: ATTACH SHORT SUPPORT LEGS (H) TO THE STORAGE FOOTBOARD (B) BY USING ALLEN KEY (a), BOLT (e), SPRING WASHER (c), FLAT WASHER (d).
 STEP 4: HANG SIDE RAILS (C) TO THE HEADBOARD POST (F) AND FOOTBOARD (B).
 STEP 5: SECURE SIDE RAILS (C) WITH HEADBOARD POST (F) BY USING SCREW (f).
 STEP 6: ATTACH LONG SUPPORT LEG (I) TO SLATS ROLL (E) BY TURNING CLOCKWISE.
 STEP 7: ATTACH SLATS (E) TO SIDE RAILS (C) BY USING SCREW (g).

IMPORTANT NOTE:

- HARDWARE BAG FOR HEADBOARD IS PACKED WITH HEADBOARD.
- HARDWARE BAG FOR FOOTBOARD AND SLATS IS PACKED WITH FOOTBOARD.

Made In Vietnam