

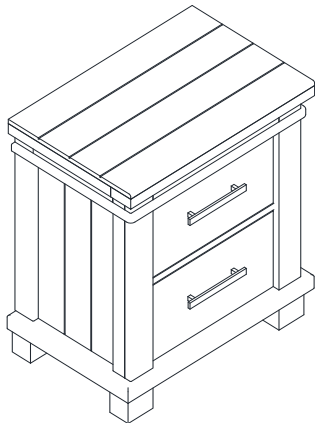

ASSEMBLY INSTRUCTIONS

ITEM NO.: 2650-36
NIGHT STAND

THANK YOU FOR PURCHASING THIS QUALITY PRODUCT. BE SURE TO CHECK ALL PACKING MATERIAL CAREFULLY FOR SMALL PARTS THAT MAY HAVE COME LOOSE INSIDE THE CARTON DURING SHIPMENT.

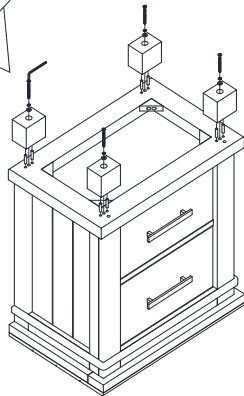
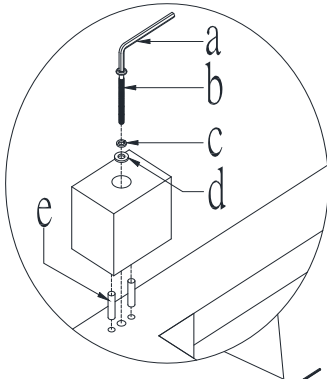

TOOLS REQUIRED (NOT PROVIDED)

PHILLIPS SCREWDRIVER



PARTS LIST:

NO	DESCRIPTION	SKETCH	QTY
A	NIGHT STAND		1 PC
B	BUN FEET		4 PCS

HARDWARE LIST:

NO	DESCRIPTION	SKETCH	SIZE	QTY
a	Allen Key		4 x 74 x 29mm	1 PC
b	Bolt		ϕ 1/4"x 15 x 70mm	4 PCS
c	Spring Washer		ϕ 1/4"x ϕ 11x 2mm T	4 PCS
d	Flat Washer		ϕ 1/4"x ϕ 18 x 2mm T	4 PCS
e	WOODEN DOWEL		10*40mm	8 PCS
f	STRAIGHT ALLEN KEY		4*100mm	1PC
g	TIPPING RESTRAINT			1 set

STEP 1: Lay the night stand (A) up side down on a soft surface. Insert wooden dowel (e) to the bottom of night stand (A). Attach bun feet (B) by using allen key (a), bolt (b), spring washer (c), flat washer (d).

Important note:

The hardware bag is packed with NIGHT STAND.