



ASSEMBLY INSTRUCTION

2293 - 334 - TWIN UPHOLSTERED LIGHT UP HEADBOARD / FOOTBOARD / SLATS

2293 - 350 - TWIN / FULL SIDERAILS - SULLIVAN WALNUT

Thank you for purchasing this quality product. Be sure to check all packing material carefully for small parts that may have come loose inside the carton during shipment.

TOOLS REQUIRED (NOT PROVIDED):
PHILIPS SCREW DRIVER

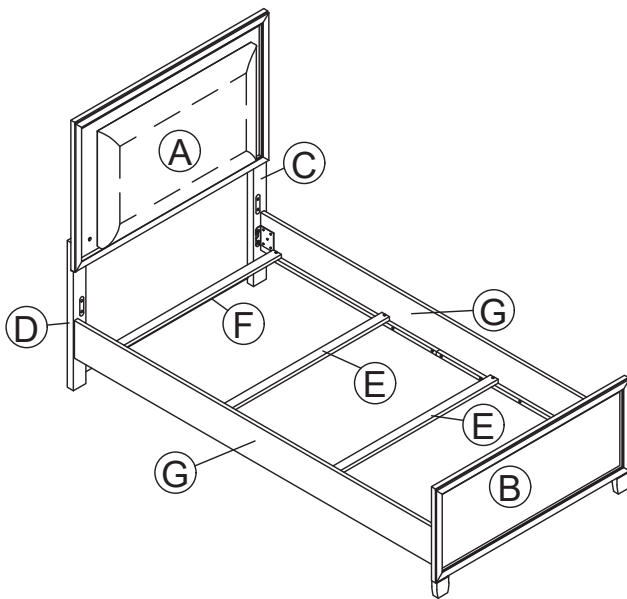

**COMPLETE BED
WITHOUT STORAGE**

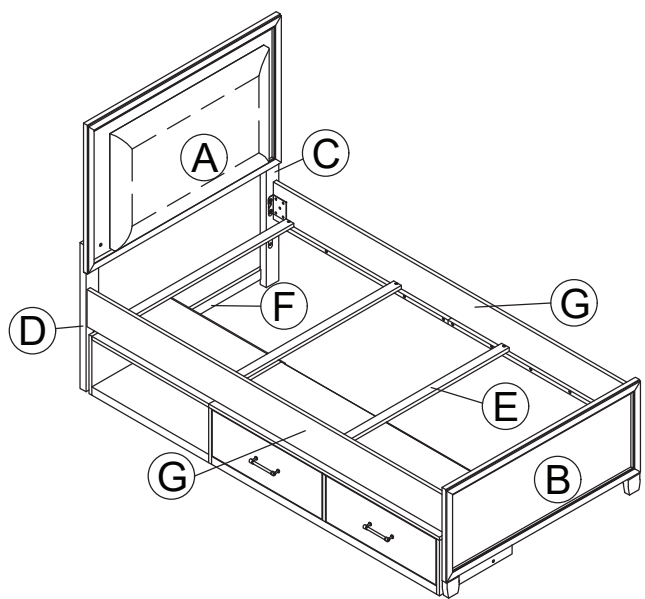

**COMPLETE BED
WITH STORAGE**

HARDWARE LIST

No	Description	Q'ty
1	JCBC Nylok Bolt M6 x 30mm	6
2	Spring Washer Ø1/4"	6
3	Flat Washer Ø1/4" x 13mm	6
4	CSK Screw M4 x 32mm	10
5	L Key M4	1
6	L Key M5	1
7	I Key M4	1
8	I Key M5	1
9	LED Adapter	1
10	JCBC Nylok Bolt M8 x 14mm	8

PARTS LIST

No	Description	Picture	Q'ty
A	Headboard Panel		1
B	Footboard Panel		1
C	Headboard Leg (R)		1
D	Headboard Leg (L)		1
E	Bed Slat (18mm x 45mm x 1008mm)		4
F	Headboard Rail Support		1
G	Side Rail		2



ASSEMBLY INSTRUCTION

2293 - 334 - TWIN UPHOLSTERED LIGHT UP HEADBOARD / FOOTBOARD / SLATS

2293 - 350 - TWIN / FULL SIDERAILS - SULLIVAN WALNUT

Thank you for purchasing this quality product. Be sure to check all packing material carefully for small parts that may have come loose inside the carton during shipment.

STEP 1 - FIGURE 1

Attach & tighten the Headboard Leg (C/D) to the Headboard Panel (A). Using JCBC Nylok Bolt M6 x 30mm (1), Spring Washer $\varnothing \frac{1}{4}$ " (2), Flat Washer $\varnothing \frac{1}{4}$ " x 13mm (3) using L key M4 (5) or I Key M4 (7) provided.

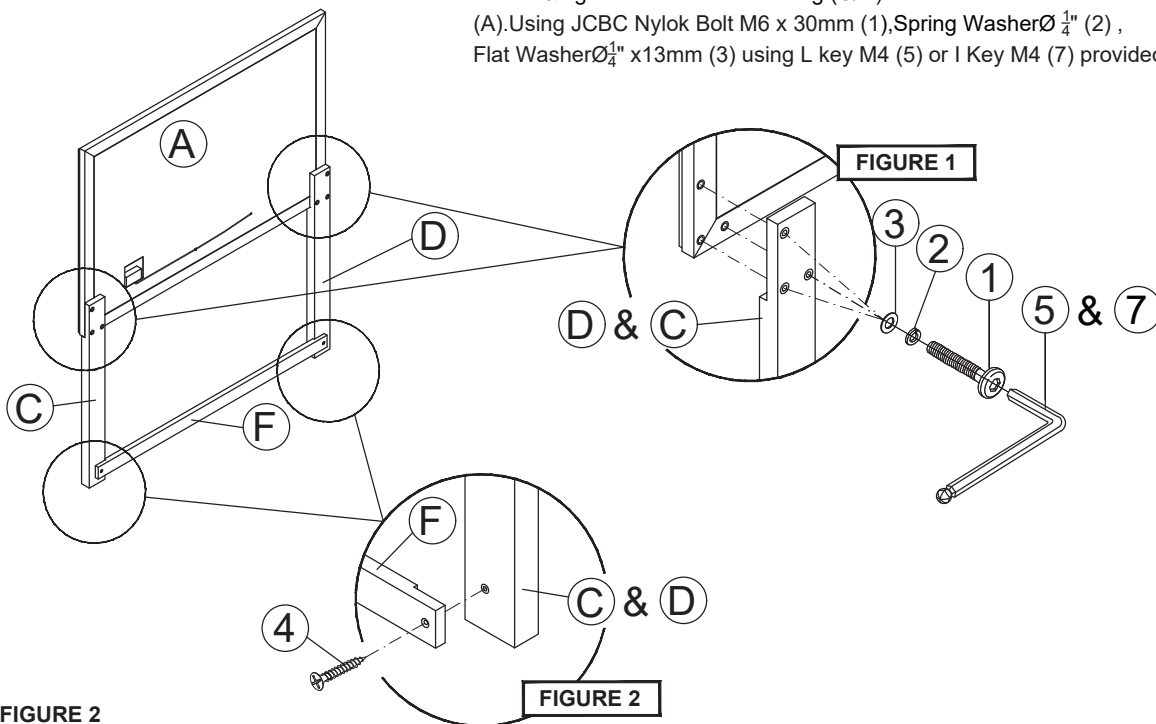

STEP 2 - FIGURE 2

Attach Headboard Rail Support (F) using CSK screw M4 x 32mm (4).

STEP 3 - FIGURE 3

Attach Side Rail (G) to Headboard Leg (C/D). Tighten JCBC Nylok Bolt M8 (10) to Headboard Leg (C/D) by using L Key M5 (6) or I Key M5 (8) and repeat the same step on Footboard Panel (B).
Note: Attach Side Rail (G) to top of hook plate for use of Storage Unit.

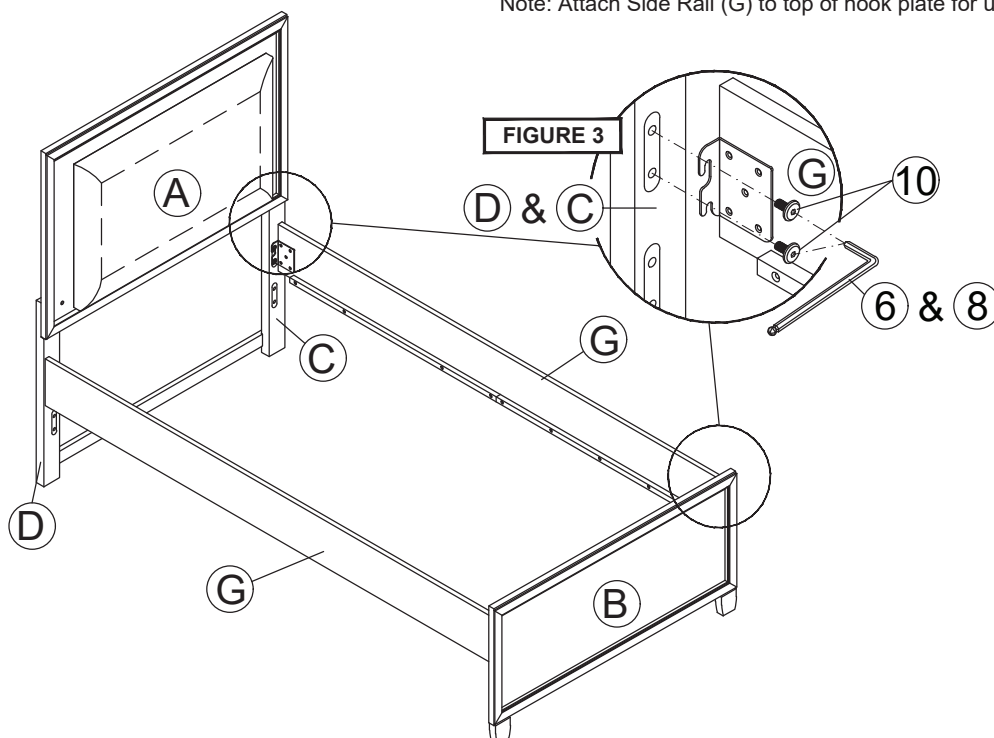



ASSEMBLY INSTRUCTION

2293 - 334 - TWIN UPHOLSTERED LIGHT UP HEADBOARD / FOOTBOARD / SLATS

2293 - 350 - TWIN / FULL SIDERAILS - SULLIVAN WALNUT

Thank you for purchasing this quality product. Be sure to check all packing material carefully for small parts that may have come loose inside the carton during shipment.

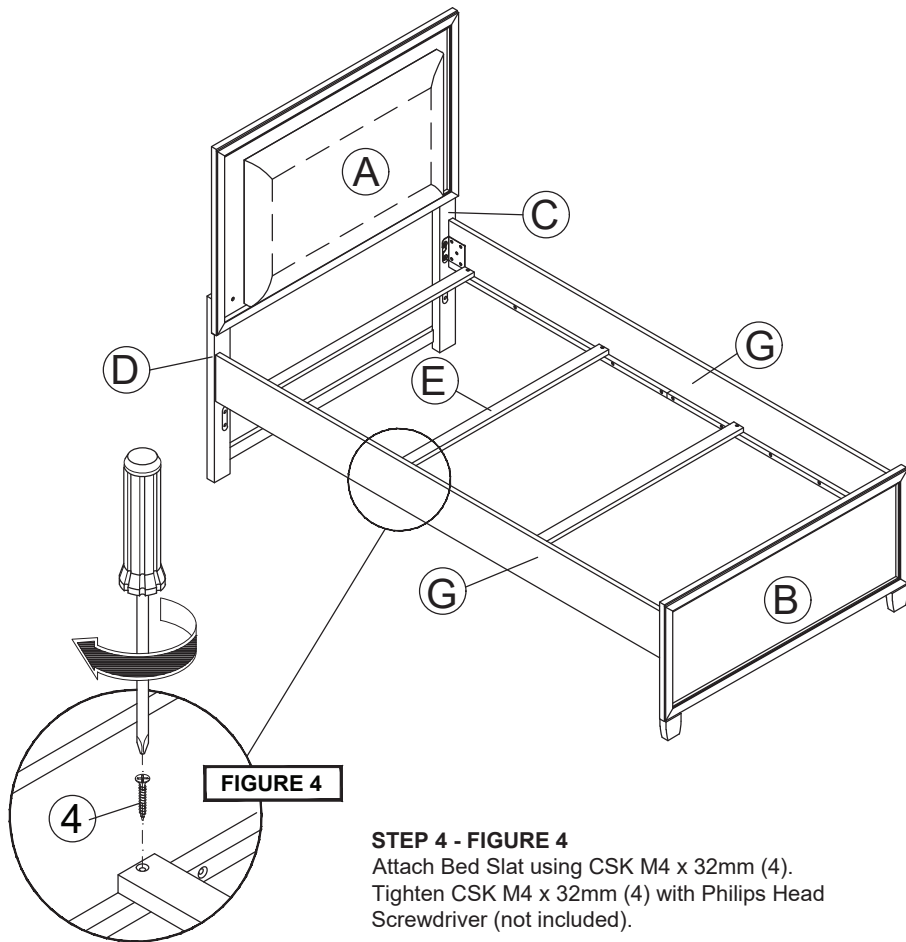

STEP 4 - FIGURE 4
Attach Bed Slat using CSK M4 x 32mm (4).
Tighten CSK M4 x 32mm (4) with Philips Head
Screwdriver (not included).

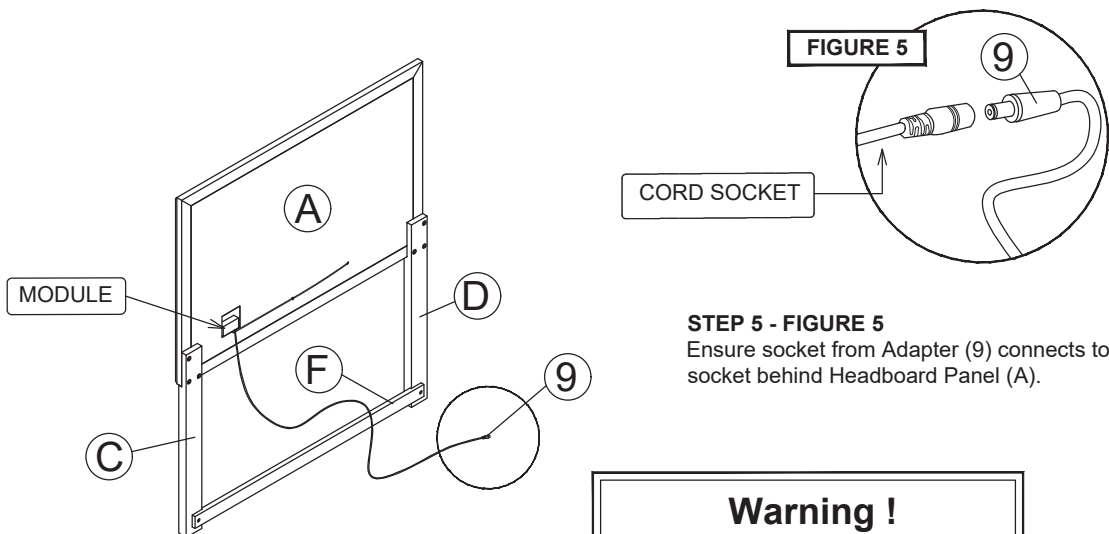

STEP 5 - FIGURE 5
Ensure socket from Adapter (9) connects to
socket behind Headboard Panel (A).

Warning !

Caution ! : Please do not touch
the chrome button with wet hand.



ASSEMBLY INSTRUCTION

2293 - 001 - UNDERBED STORAGE UNIT- SULLIVAN WALNUT

Thank you for purchasing this quality product. Be sure to check all packing material carefully for small parts that may have come loose inside the carton during shipment.



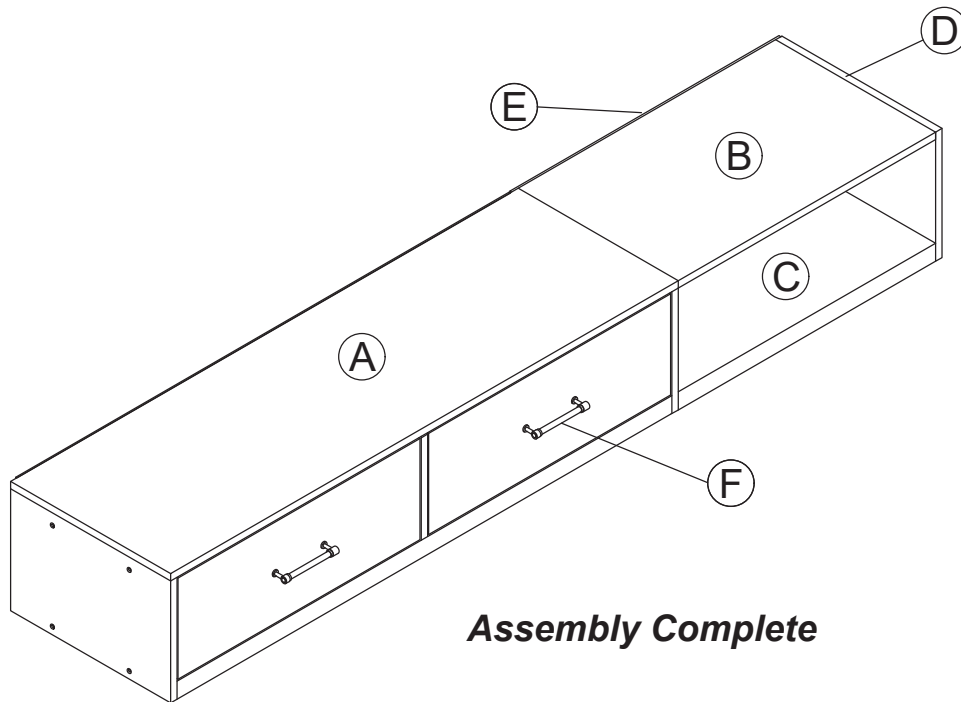



TOOLS REQUIRED (NOT PROVIDED):
PHILIPS SCREW DRIVER



HARDWARE LIST

No	Description	Q'ty
1	 JCBC Nylok Bolt M6 x 35mm	8
2	 JCBC M6 Sleeve Nut	4
3	 Spring Washer Ø1/4"	8
4	 Flat Washer Ø1/4" x 20mm	8
5	 Pan Head Screw M4x16mm	16
6	 L Key M4	1
7	 I Key M4	1
8	 JCBC Nylok Bolt M6 x 12mm	2

PARTS LIST

No	Description	Picture	Q'ty
A	Storage Unit		1
B	Top		1
C	Bottom		1
D	Side Panel		1
E	Back Panel		1
F	Handle		2



ASSEMBLY INSTRUCTION

2293 - 001 - UNDERBED STORAGE UNIT- SULLIVAN WALNUT

Thank you for purchasing this quality product. Be sure to check all packing material carefully for small parts that may have come loose inside the carton during shipment.

STEP 1 - FIGURE 1

Begin assembly by attaching Top (B) and Bottom (C) to Storage Unit (A) using to JCBC Nylok Bolt M6 x 35mm (1) ,Spring Washer Ø1/4" (3) & Flat Washer Ø1/4" x 20mm (4). Attach Side Panel (D) using JCBC Nylok Bolt M6 x 35mm (1) ,Spring Washer Ø1/4"(3) & Flat Washer Ø1/4" x 20mm (4) and JCBC M6 Sleeve Nut (2). Tighten using L Key M4 (6) or I Key M4 (7) provided.

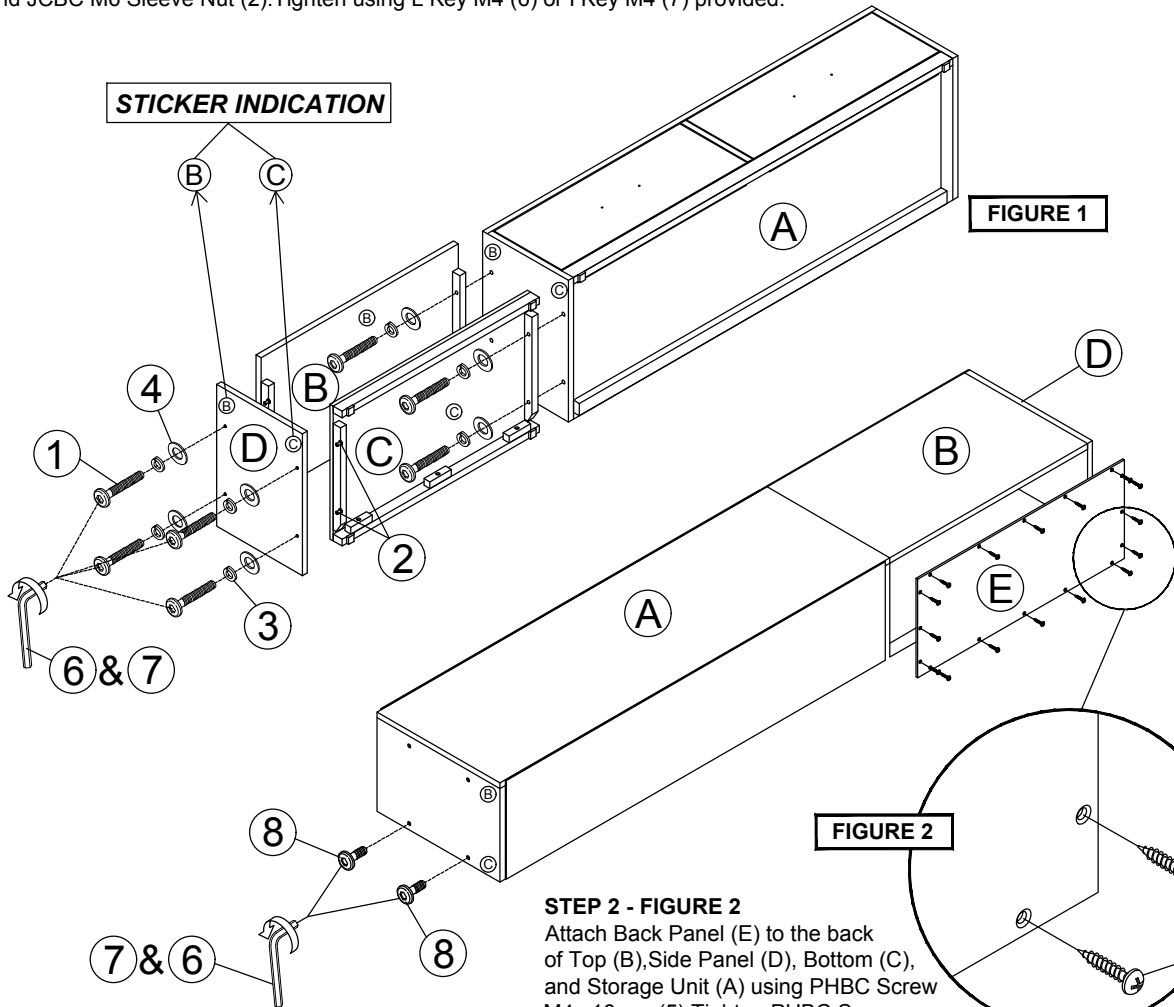

STEP 2 - FIGURE 2

Attach Back Panel (E) to the back of Top (B), Side Panel (D), Bottom (C), and Storage Unit (A) using PHBC Screw M4 x16mm (5). Tighten PHBC Screw M4 x16mm (5) with Philips Head Screwdriver (not included). Attach JCBC Nylok Bolt M6 x 12mm (8) to the other end of Storage Unit (A), tighten with L Key M4 (6) or I Key M4 (7) provided.

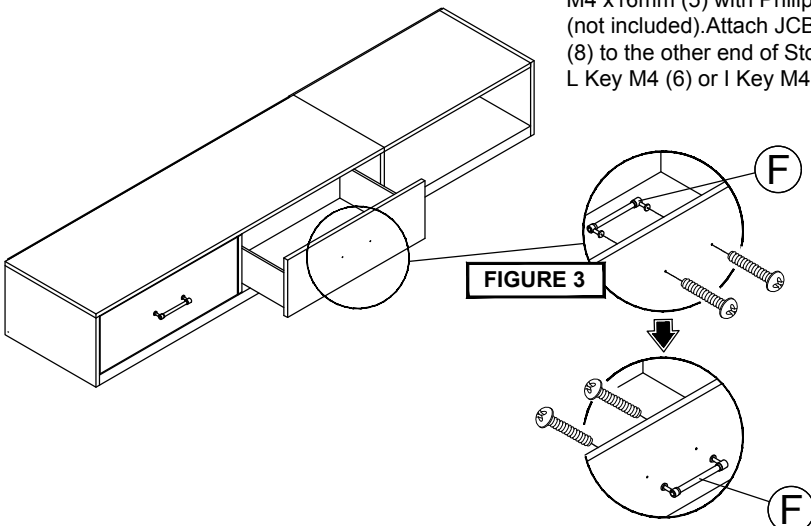

STEP 3 - FIGURE 3

Handles (F) and screws are pre assembled to drawer faces. Unscrew and attach handle on the outside by securing it from the inside with the screws that have been removed. Make sure to hold drawers in place. Tighten all handles from the inside. Do not overtighten.



ASSEMBLY INSTRUCTION

2293 - 717 - DRESSER - SULLIVAN WALNUT

Thank you for purchasing this quality product. Be sure to check all packing material carefully for small parts that may have come loose inside the carton during shipment.

TOOLS REQUIRED (NOT PROVIDED):
PHILIPS SCREW DRIVER



PART LIST

No.	Description	Picture	Q'ty
A	Drawer Dresser		1
B	Bun Foot		4
C	Handle		6
D	Support Leg		1

HARDWARE LIST

No.	Description	Picture	Q'ty
1	Wood Dowel 10mm x30mm		4
2	JCBC Nylok Bolt M6 x 50mm		4
3	Spring Washer Ø1/4"		4
4	Flat Washer Ø1/4" x 13mm		4
5	L Key M4		1
6	I Key M4		1
7	Tip Restraint Kit		1

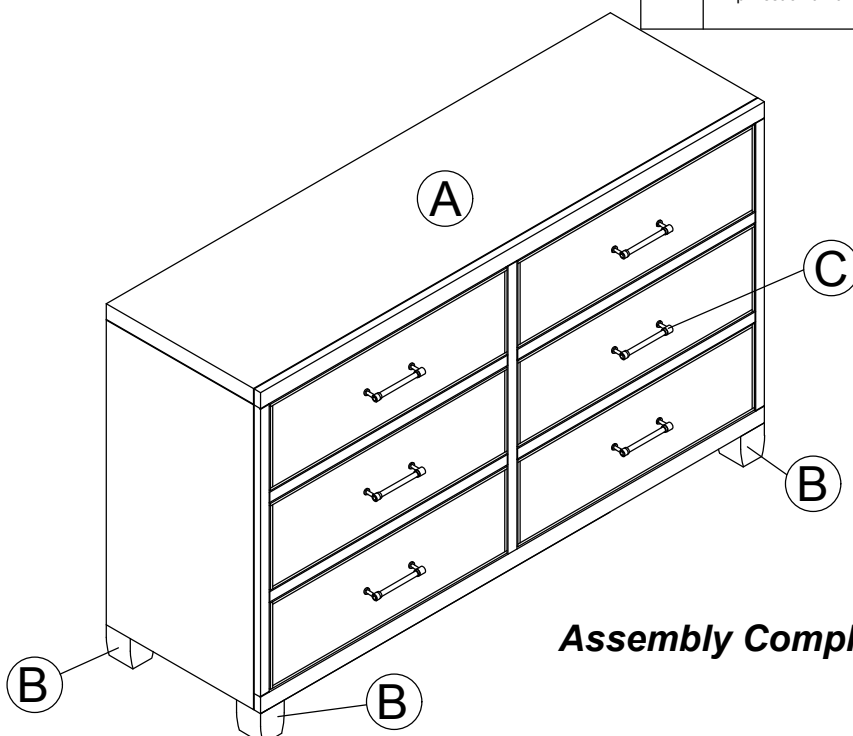

Assembly Complete



ASSEMBLY INSTRUCTION

2293 - 717 - DRESSER - SULLIVAN WALNUT

Thank you for purchasing this quality product. Be sure to check all packing material carefully for small parts that may have come loose inside the carton during shipment.

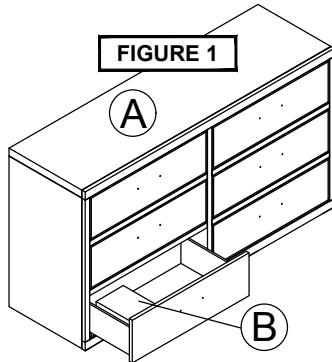

STEP 1 - FIGURE 1
Begin assembly by removing Bun Foot (B) Support Leg (C) from drawer in Dresser (A).

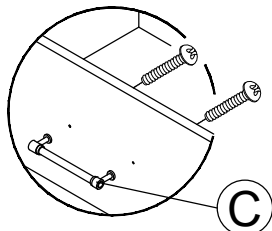
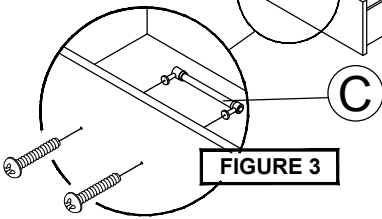
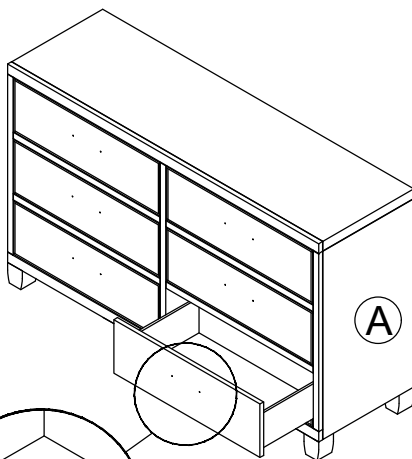

STEP 3 - FIGURE 3
Remove Handles (C) from drawers and then turn around and secure from the front. Tighten screws with Philips Screwdriver (not included).

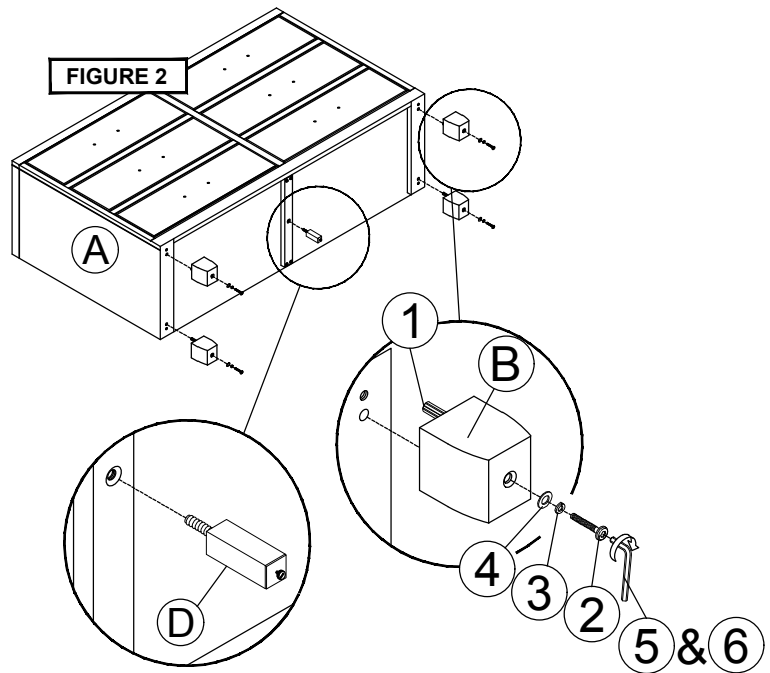

STEP 2 - FIGURE 2

Insert Wood Dowel 10mm x 30mm (1) into each Bun Foot (B). Attach Bun Foot (B) to bottom of Dresser (A) using JCBC Nylok Bolt M6 x 50mm (2), Spring Washer $\text{\O} \frac{1}{4}$ " (3) & Flat Washer $\text{\O} \frac{1}{4}$ " x 13mm (4). Tighten using L Key M4 (5) or I Key M4 (6) provided. Attach Support Leg (D) to Dresser (A).

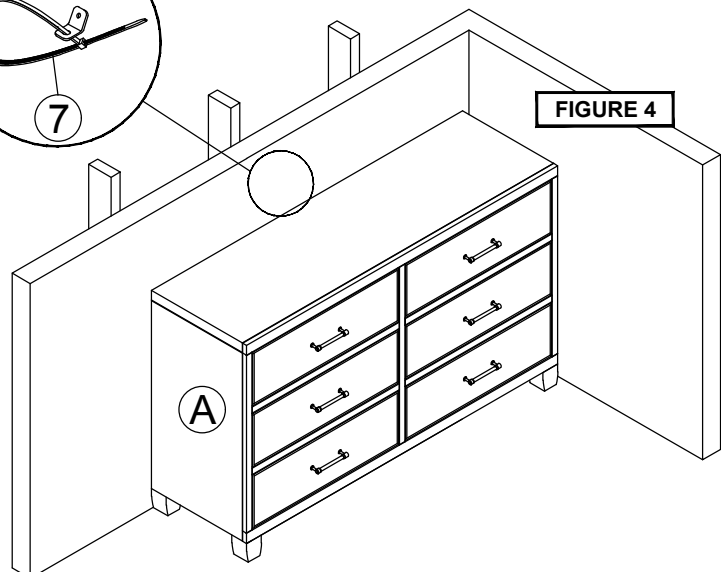
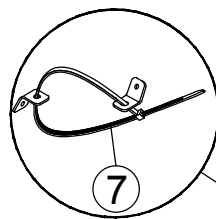

STEP 4 - FIGURE 4
Attach one end of Tip Restraint Kit (7) to wall and the other end to Dresser (A). The assembly is now complete.



ASSEMBLY INSTRUCTION



2293 - 721 - MIRROR - SULLIVAN WALNUT

Thank you for purchasing this quality product. Be sure to check all packing material carefully for small parts that may have come loose inside the carton during shipment.





TOOLS REQUIRED (NOT PROVIDED):
PHILIPS SCREW DRIVER



PART LIST

No.	Description	Picture	Q'ty
A	Dresser		1
B	Mirror		1
C	Mirror Support		2

HARDWARE LIST

No.	Description	Picture	Q'ty
1	JCBC Nylok Bolt M6 x 35mm		8
2	Spring Washer Ø1/4"		8
3	Flat Washer Ø1/4" x 20mm		8
4	L Key M4		1
5	I Key M4		1

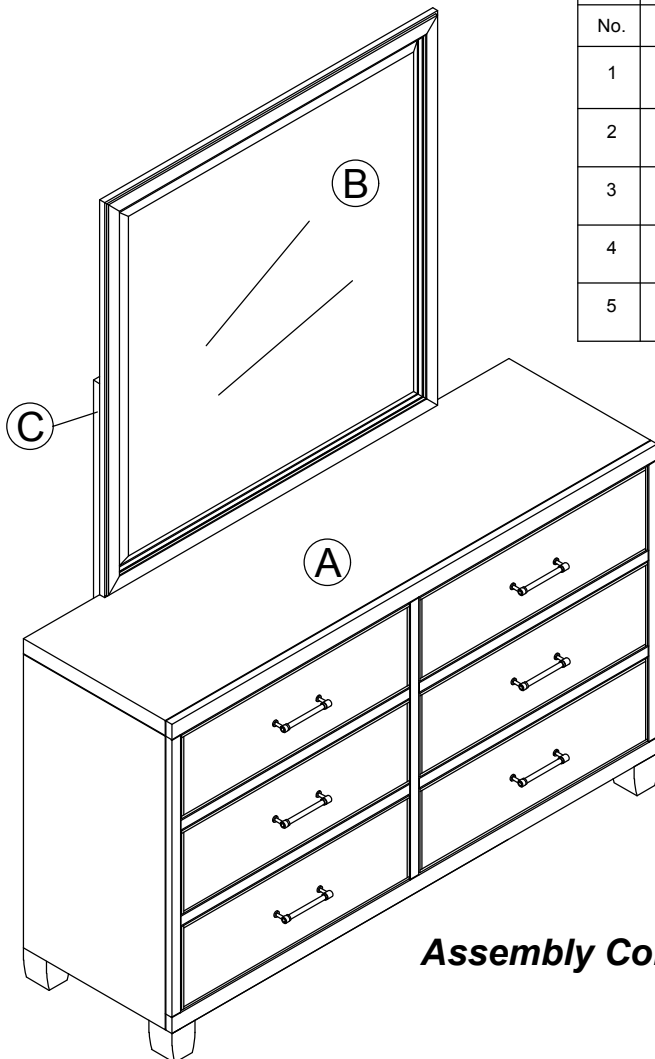

Assembly Complete



ASSEMBLY INSTRUCTION

2293 - 721 - MIRROR - SULLIVAN WALNUT

Thank you for purchasing this quality product. Be sure to check all packing material carefully for small parts that may have come loose inside the cartons during shipment.

STEP 1 - FIGURE 1

Begin assembly by attaching each Mirror Support (C) to back of Mirror (B) using JCBC Nylok Bolt M6 x 35mm (1), Spring Washer $\varnothing 1/4"$ (2) & Flat Washer $\varnothing 1/4" \times 20\text{mm}$ (3). Tighten using L Key M4 (4) or I Key M4 (5) provided.

