



## ASSEMBLY INSTRUCTION

**2293 - 464 - FULL UPHOLSTERED LIGHT UP HEADBOARD / FOOTBOARD SLATS**

**2293 - 350 - TWIN / FULL SIDERAILS - SULLIVAN WALNUT**

Thank you for purchasing this quality product. Be sure to check all packing material carefully for small parts that may have come loose inside the carton during shipment.

TOOLS REQUIRED (NOT PROVIDED):  
PHILIPS SCREW DRIVER

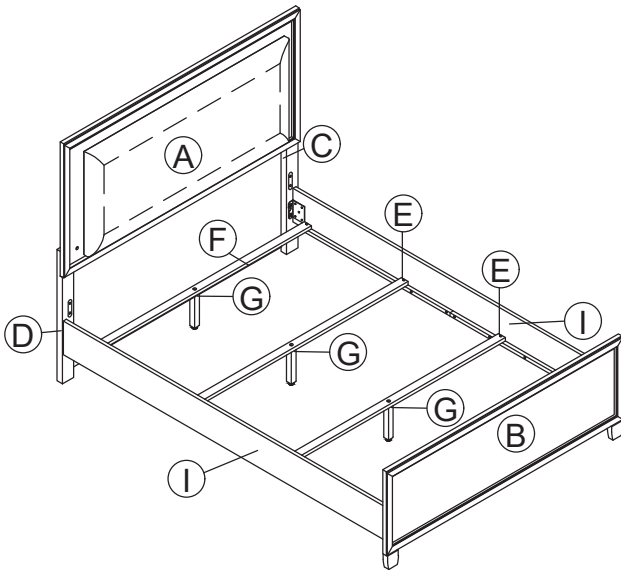

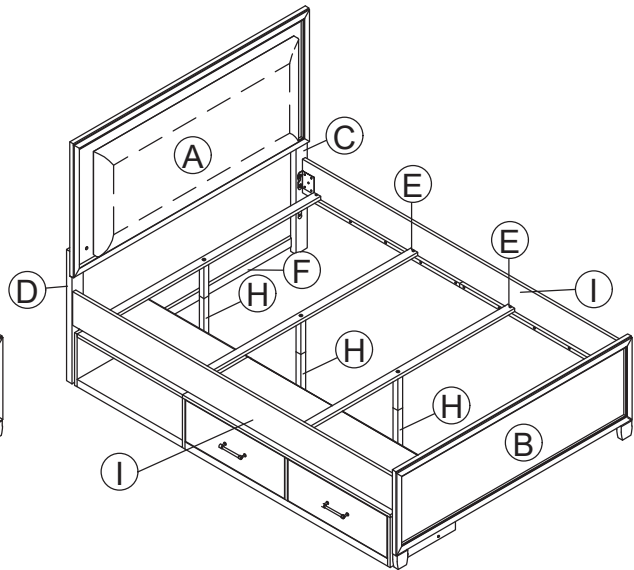

**COMPLETE BED  
WITHOUT STORAGE**











**COMPLETE BED  
WITH STORAGE**

### HARDWARE LIST

No	Description	Q'ty
1	 JCBC Nylok Bolt M6 x 30mm	6
2	 JCBC Nylok Bolt M6 x 50mm	4
3	 Spring Washer Ø1/4"	6
4	 Flat Washer Ø1/4" x 13mm	6
5	 CSK Screw M4 x 32mm	10
6	 L Key M4	1
7	 L Key M5	1
8	 I Key M4	1
9	 I Key M5	1
10	 LED Adapter	1
11	 JCBC Nylok Bolt M8 x 14mm	8

### PARTS LIST

No	Description	Picture	Q'ty
A	Headboard Panel		1
B	Footboard Panel		1
C	Headboard Leg (R)		1
D	Headboard Leg (L)		1
E	Bed Slat (18mm x 45 mm x 1387 mm)		4
F	Headboard Rail Support		1
G	Bed Slat Top Support Leg (29mm x 29mm x 155mm)		4
H	Bed Slat Lower Support Leg (29mm x 29mm x 175mm)		4
I	Side Rail		2



**ASSEMBLY INSTRUCTION**

**2293 - 464 - FULL UPHOLSTERED LIGHT UP HEADBOARD / FOOTBOARD SLATS**

**2293 - 350 - TWIN / FULL SIDERAIL - SULLIVAN WALNUT**

Thank you for purchasing this quality product. Be sure to check all packing material carefully for small parts that may have come loose inside the carton during shipment.

**STEP 1 - FIGURE 1**

Attach & tighten the Headboard Leg (C/D) to the Headboard Panel (A). Using JCBC Nylok Bolt M6 x 30mm (1), Spring Washer (3), Flat Washer (4) using L key M4 (6) or I Key M4 (8) provided.

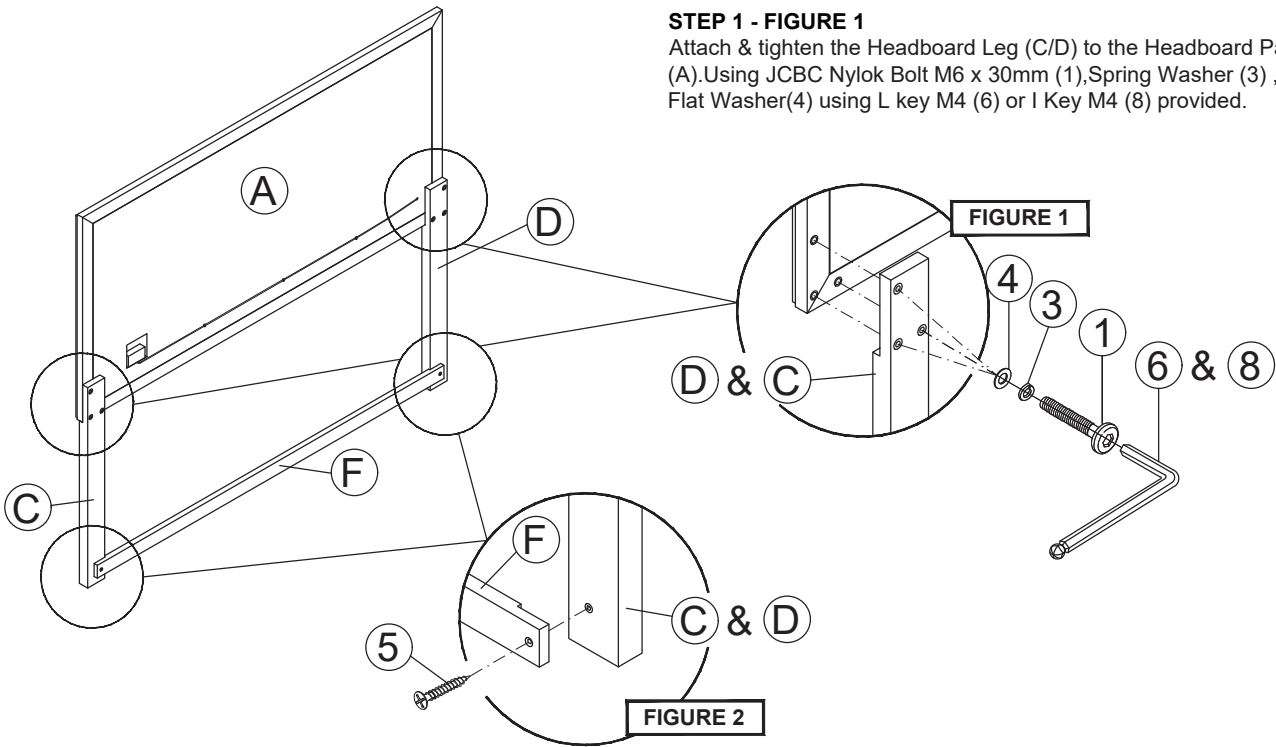

**STEP 2 - FIGURE 2**

Attach Headboard Rail Support (F) using CSK screw M4 x 32mm (5).

**STEP 3 - FIGURE 3**

Attach Side Rail (I) to Headboard Leg (C/D). Tighten M8 JCBC Nylok Bolt (11) to Headboard Leg (C/D) by using L Key M5 (7) or I Key M5 (9) and repeat the same step on Footboard Panel (B). Note: Attach Side Rail (I) to top of hook plate for use of Storage Unit.

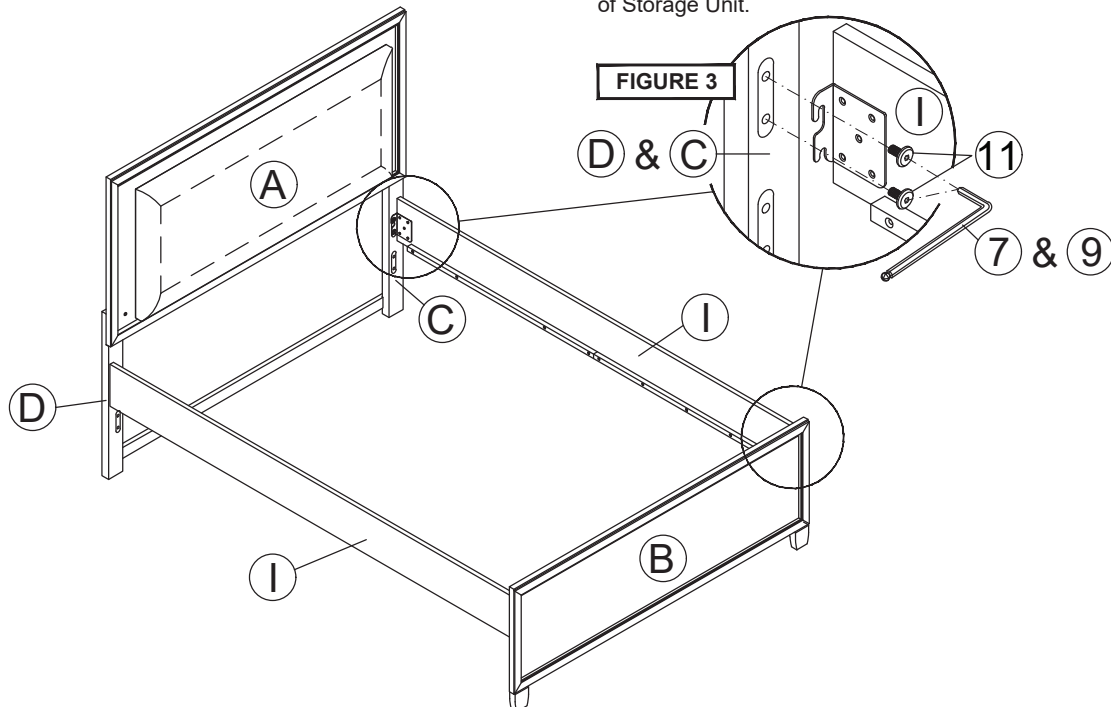

**ASSEMBLY INSTRUCTION**  
**2293 - 464 - FULL UPHOLSTERED LIGHT UP HEADBOARD / FOOTBOARD SLATS**  
**2293 - 350 - TWIN / FULL SIDERAIL - SULLIVAN WALNUT**

Thank you for purchasing this quality product. Be sure to check all packing material carefully for small parts that may have come loose inside the carton during shipment.

**STEP 4 - FIGURE 4 WITHOUT STORAGE UNIT**

Attach the Bed Slat Lower Support Leg (H) to Bed Slat (E) using JCBC Nylok Bolt M6 x 50mm (2). Tighten screws with L Key (6) or I Key (8) provided.

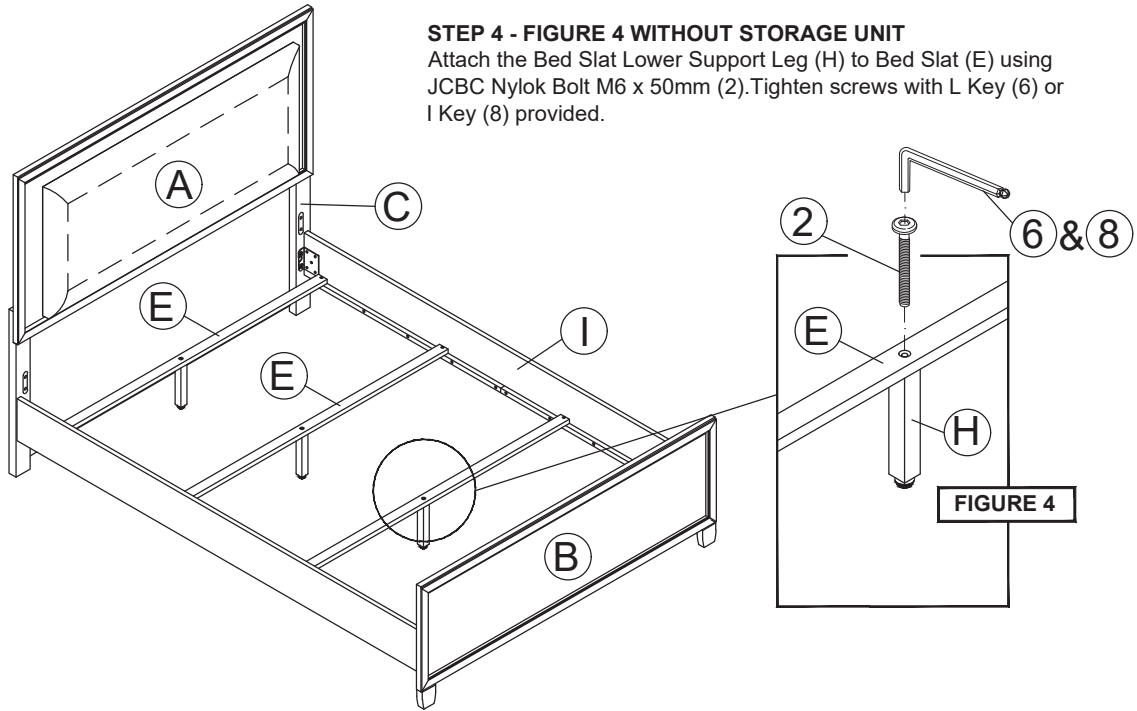

**STEP 5 - FIGURE 5 WITH STORAGE UNIT**

Attach Bed Slat Top Support Leg (G) to Bed Slat (E) using JCBC Nylok Bolt M6 X 50mm (2). Tighten screws with L Key M4 (6) or I Key M4 (8) provided. Next attach Bed Slat Lower Support Leg (H) to Bed Slat Top Support Leg (G).

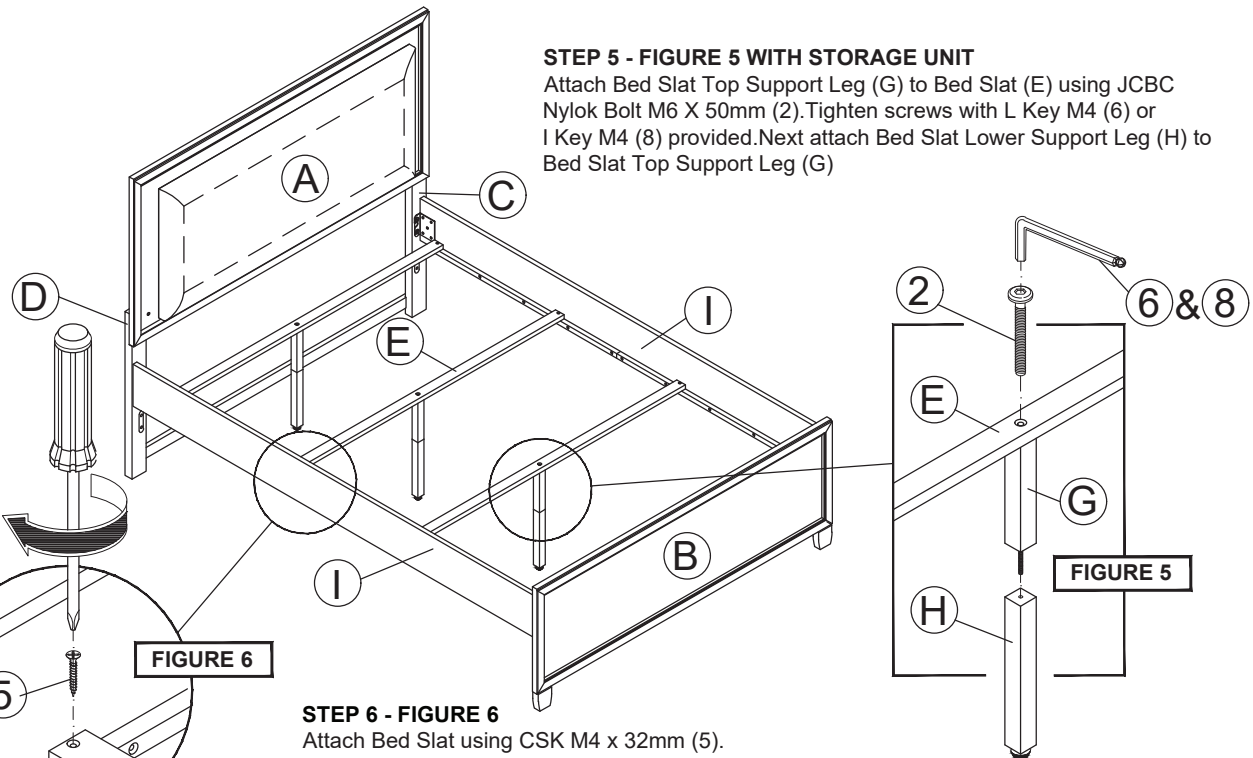

**FIGURE 6**

**STEP 6 - FIGURE 6**

Attach Bed Slat using CSK M4 x 32mm (5). Tighten CSK M4 x 32mm (5) with Philips Head Screwdriver (not included).



**ASSEMBLY INSTRUCTION**  
**2293 - 464 - FULL UPHOLSTERED LIGHT UP HEADBOARD / FOOTBOARD**  
**SLATS**  
**2293 - 350 - TWIN / FULL SIDERAIL - SULLIVAN WALNUT**

Thank you for purchasing this quality product. Be sure to check all packing material carefully for small parts that may have come loose inside the carton during shipment.

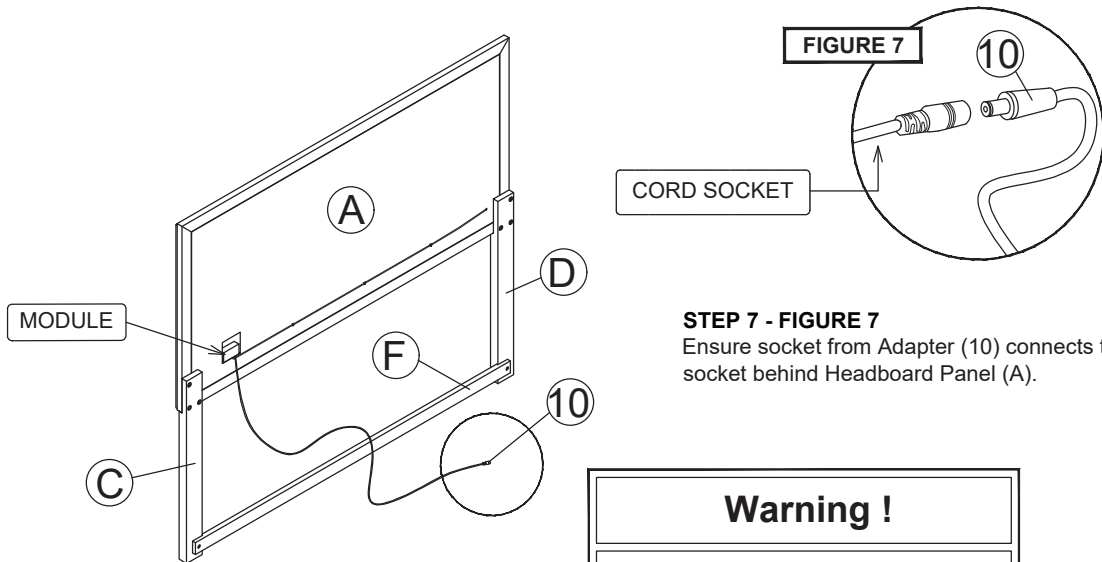

**STEP 7 - FIGURE 7**  
Ensure socket from Adapter (10) connects to socket behind Headboard Panel (A).

**Warning !**

**Caution ! : Please do not touch the chrome button with wet hand.**



**ASSEMBLY INSTRUCTION**

**2293 - 001 - UNDERBED STORAGE UNIT- SULLIVAN WALNUT**

Thank you for purchasing this quality product. Be sure to check all packing material carefully for small parts that may have come loose inside the carton during shipment.

TOOLS REQUIRED (NOT PROVIDED):  
PHILIPS SCREW DRIVER

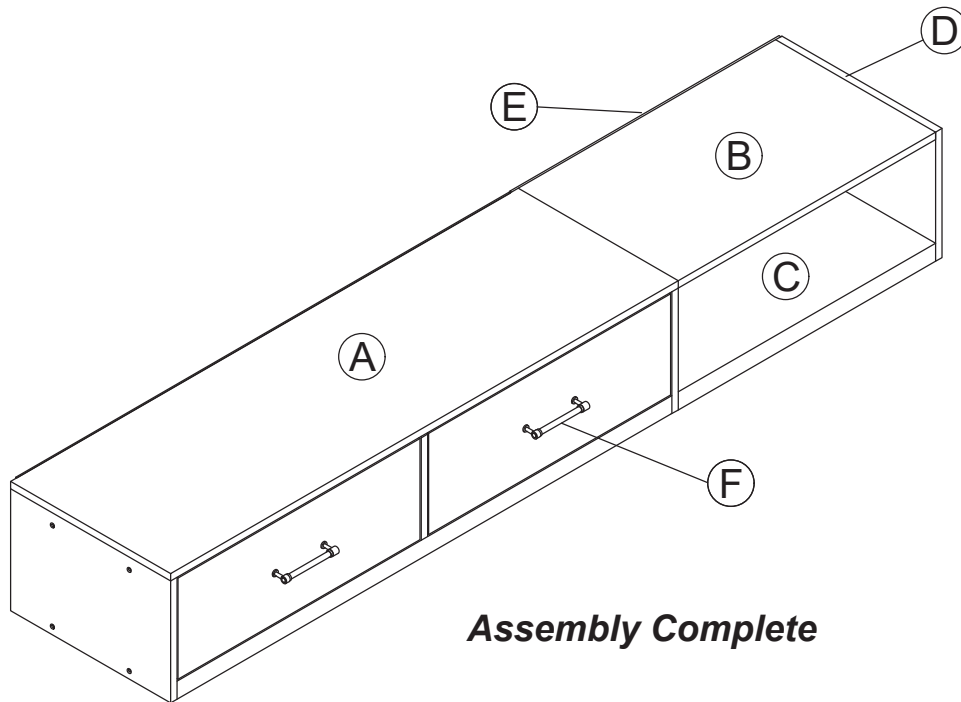







**Assembly Complete**

**HARDWARE LIST**

No	Description	Q'ty
1	 JCBC Nylok Bolt M6 x 35mm	8
2	 JCBC M6 Sleeve Nut	4
3	 Spring Washer Ø1/4"	8
4	 Flat Washer Ø1/4" x 20mm	8
5	 Pan Head Screw M4x16mm	16
6	 L Key M4	1
7	 I Key M4	1
8	 JCBC Nylok Bolt M6 x 12mm	2

**PARTS LIST**

No	Description	Picture	Q'ty
A	Storage Unit		1
B	Top		1
C	Bottom		1
D	Side Panel		1
E	Back Panel		1
F	Handle		2



## ASSEMBLY INSTRUCTION

### 2293 - 001 - UNDERBED STORAGE UNIT- SULLIVAN WALNUT

Thank you for purchasing this quality product. Be sure to check all packing material carefully for small parts that may have come loose inside the carton during shipment.

#### STEP 1 - FIGURE 1

Begin assembly by attaching Top (B) and Bottom (C) to Storage Unit (A) using to JCBC Nylok Bolt M6 x 35mm (1) ,Spring Washer Ø1/4" (3) & Flat Washer Ø1/4" x 20mm (4). Attach Side Panel (D) using JCBC Nylok Bolt M6 x 35mm (1) ,Spring Washer Ø1/4"(3) & Flat Washer Ø1/4" x 20mm (4) and JCBC M6 Sleeve Nut (2). Tighten using L Key M4 (6) or I Key M4 (7) provided.

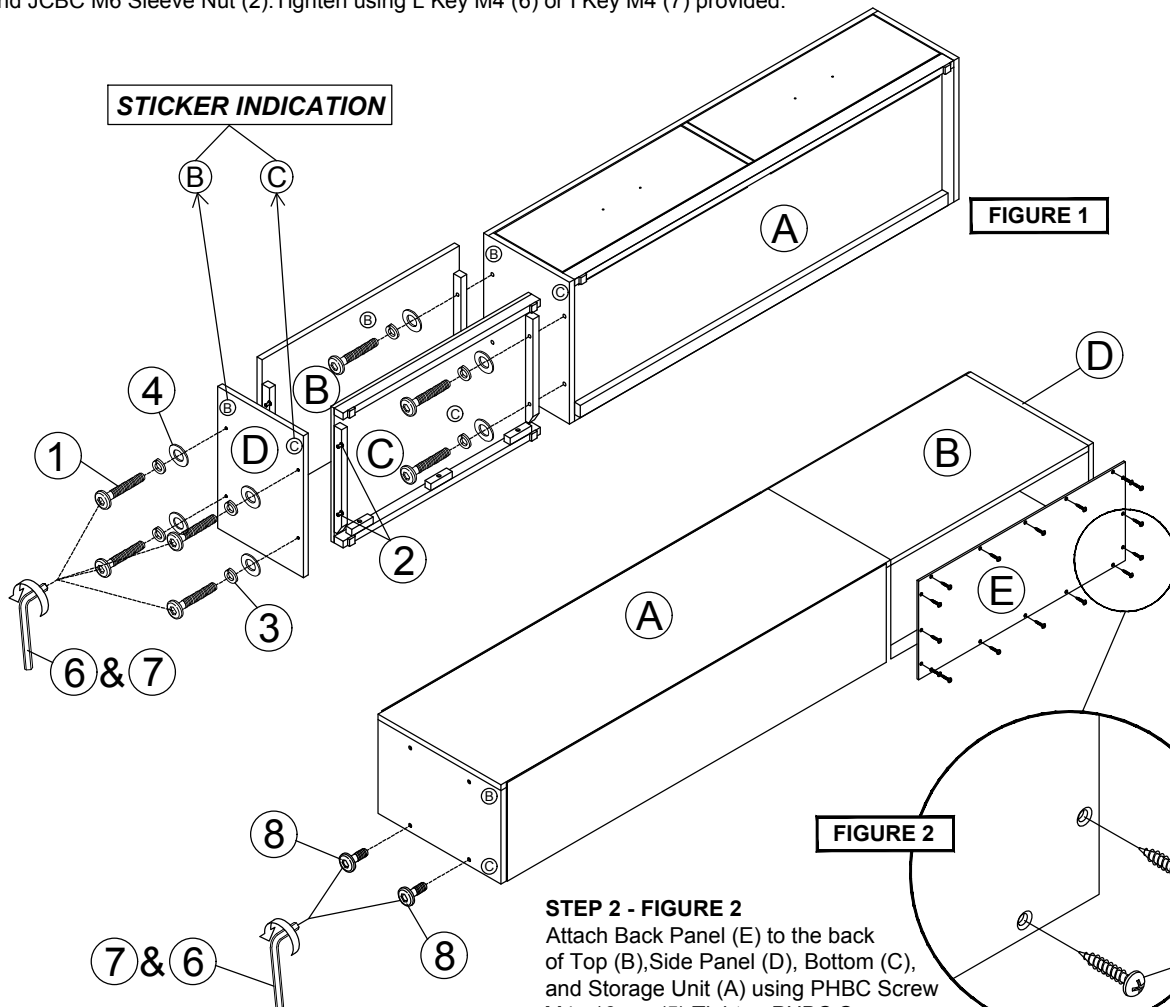

#### STEP 2 - FIGURE 2

Attach Back Panel (E) to the back of Top (B), Side Panel (D), Bottom (C), and Storage Unit (A) using PHBC Screw M4 x16mm (5). Tighten PHBC Screw M4 x16mm (5) with Philips Head Screwdriver (not included). Attach JCBC Nylok Bolt M6 x 12mm (8) to the other end of Storage Unit (A), tighten with L Key M4 (6) or I Key M4 (7) provided.

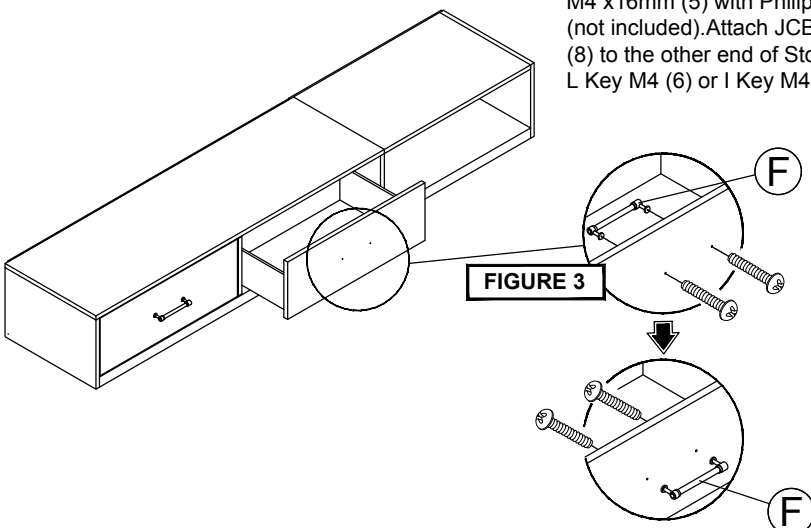

#### STEP 3 - FIGURE 3

Handles (F) and screws are pre assembled to drawer faces. Unscrew and attach handle on the outside by securing it from the inside with the screws that have been removed. Make sure to hold drawers in place. Tighten all handles from the inside. Do not overtighten.



## ASSEMBLY INSTRUCTION

### 2293 - 717 - DRESSER - SULLIVAN WALNUT

Thank you for purchasing this quality product. Be sure to check all packing material carefully for small parts that may have come loose inside the carton during shipment.

**TOOLS REQUIRED (NOT PROVIDED):**  
PHILIPS SCREW DRIVER



#### PART LIST

No.	Description	Picture	Q'ty
A	Drawer Dresser		1
B	Bun Foot		4
C	Handle		6
D	Support Leg		1

#### HARDWARE LIST

No.	Description	Picture	Q'ty
1	Wood Dowel 10mm x30mm		4
2	JCBC Nylok Bolt M6 x 50mm		4
3	Spring Washer Ø1/4"		4
4	Flat Washer Ø1/4" x 13mm		4
5	L Key M4		1
6	I Key M4		1
7	Tip Restraint Kit		1

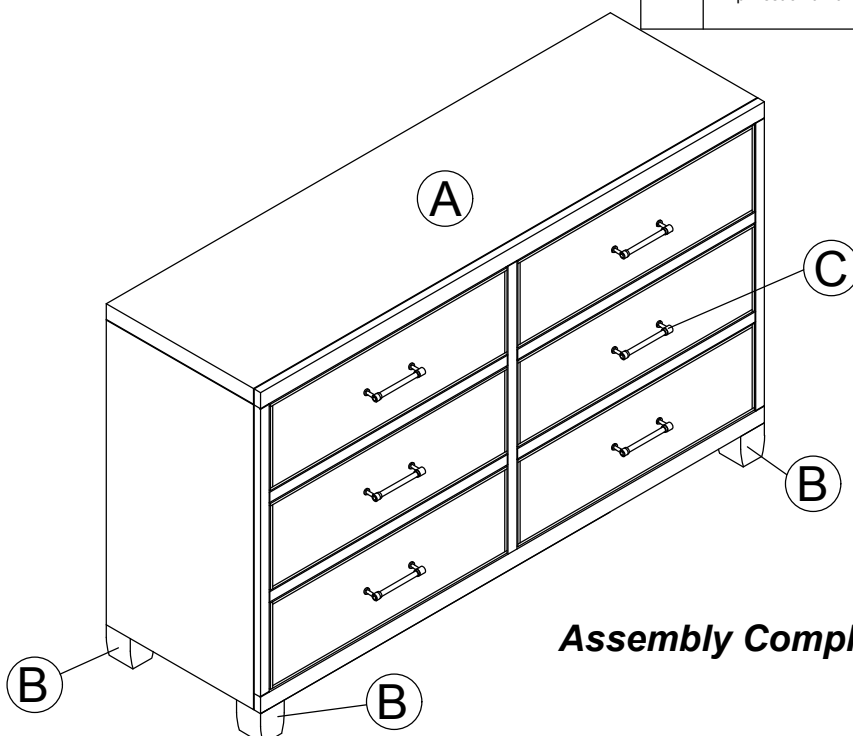

**Assembly Complete**



## ASSEMBLY INSTRUCTION

### 2293 - 717 - DRESSER - SULLIVAN WALNUT

Thank you for purchasing this quality product. Be sure to check all packing material carefully for small parts that may have come loose inside the carton during shipment.

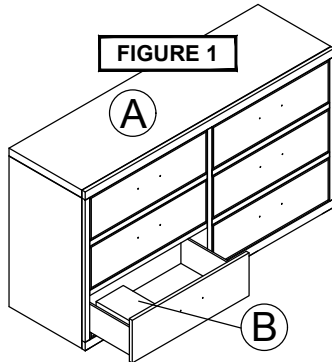

**STEP 1 - FIGURE 1**  
Begin assembly by removing Bun Foot (B) Support Leg (C) from drawer in Dresser (A).

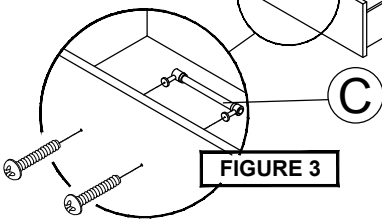
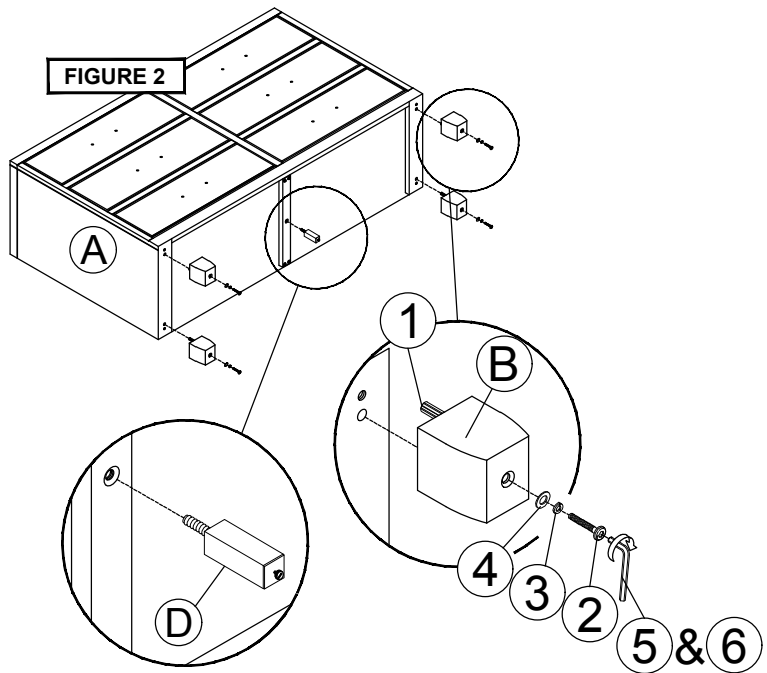
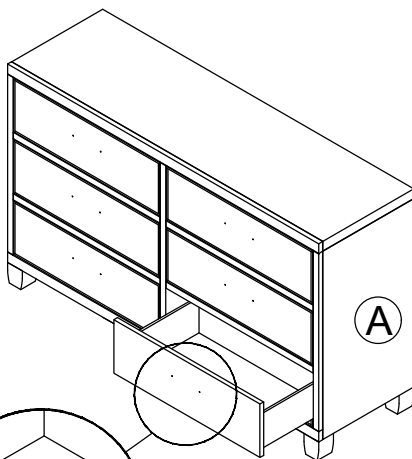

**STEP 3 - FIGURE 3**  
Remove Handles (C) from drawers and then turn around and secure from the front. Tighten screws with Philips Screwdriver (not included).

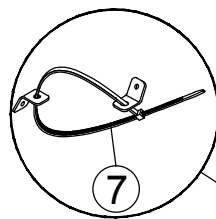

**STEP 4 - FIGURE 4**  
Attach one end of Tip Restraint Kit (7) to wall and the other end to Dresser (A). The assembly is now complete.

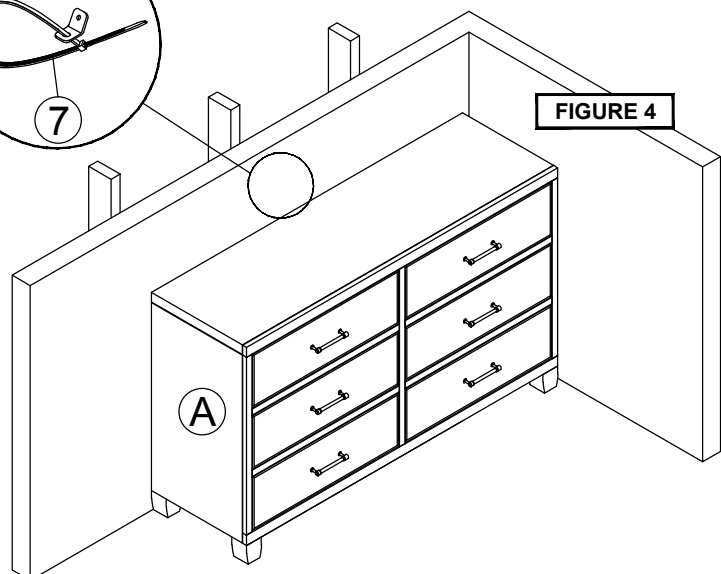





## ASSEMBLY INSTRUCTION



### 2293 - 721 - MIRROR - SULLIVAN WALNUT

Thank you for purchasing this quality product. Be sure to check all packing material carefully for small parts that may have come loose inside the carton during shipment.





**TOOLS REQUIRED (NOT PROVIDED):**  
**PHILIPS SCREW DRIVER**



#### PART LIST

No.	Description	Picture	Q'ty
A	Dresser		1
B	Mirror		1
C	Mirror Support		2

#### HARDWARE LIST

No.	Description	Picture	Q'ty
1	JCBC Nylok Bolt M6 x 35mm		8
2	Spring Washer Ø1/4"		8
3	Flat Washer Ø1/4" x 20mm		8
4	L Key M4		1
5	I Key M4		1

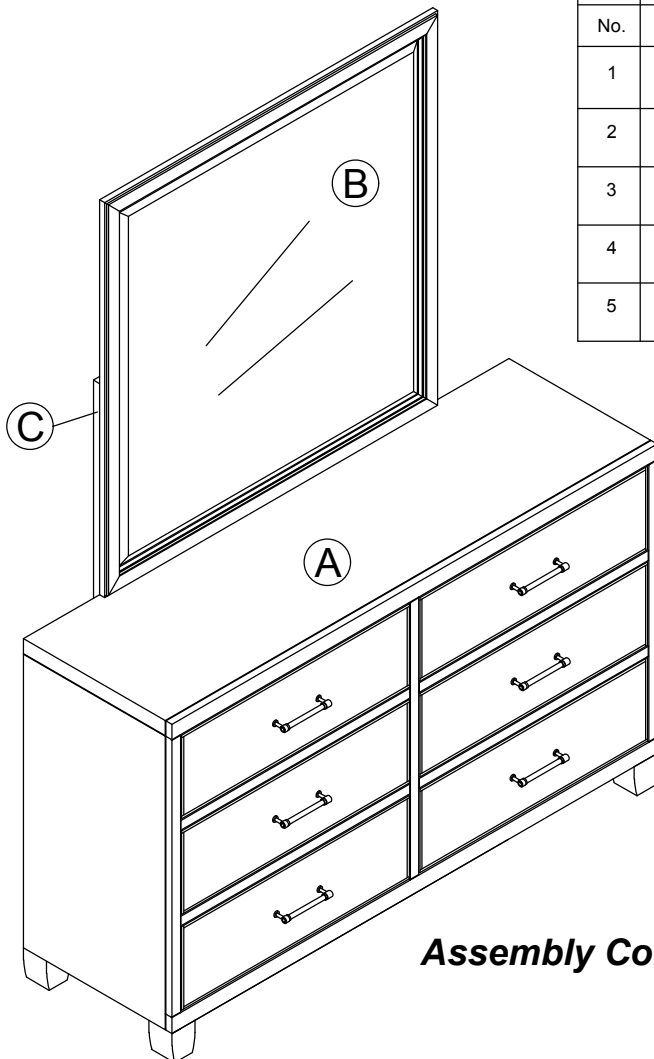

**Assembly Complete**



# ASSEMBLY INSTRUCTION

## 2293 - 721 - MIRROR - SULLIVAN WALNUT

Thank you for purchasing this quality product. Be sure to check all packing material carefully for small parts that may have come loose inside the cartons during shipment.

### STEP 1 - FIGURE 1

Begin assembly by attaching each Mirror Support (C) to back of Mirror (B) using JCBC Nylok Bolt M6 x 35mm (1), Spring Washer  $\varnothing 1/4"$  (2) & Flat Washer  $\varnothing 1/4" \times 20\text{mm}$  (3). Tighten using L Key M4 (4) or I Key M4 (5) provided.

