



AMERICAN SIGNATURE  
FURNITURE®

# ASSEMBLY INSTRUCTIONS

ITEM NO.: 2638-52B

54" TV CONSOLE-HANOVER

THANK YOU FOR PURCHASING THIS QUALITY PRODUCT. BE SURE TO CHECK ALL PACKING MATERIAL CAREFULLY FOR SMALL PARTS THAT MAY HAVE COME LOOSE INSIDE THE CARTON DURING SHIPMENT.

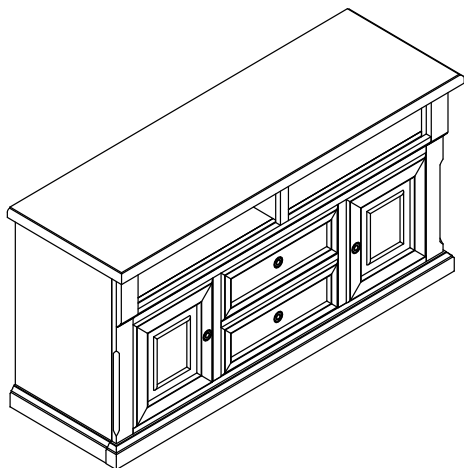

TOOLS REQUIRED (NOT PROVIDED)

PHILLIPS SCREWDRIVER

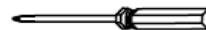

PARTS LIST:

NO	DESCRIPTION	SKETCH	QTY
A	54" TV CONSOLE		1 PC
B	BUN FEET		4 PCS
C	SUPPORT LEG		1 PC

HARDWARE LIST:

NO	DESCRIPTION	SKETCH	SIZE	QTY
a	TIPPING RESTRAINT			1 set

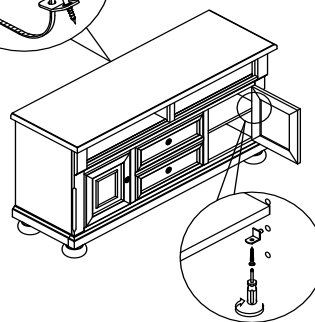
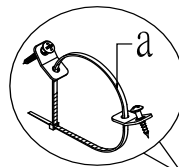
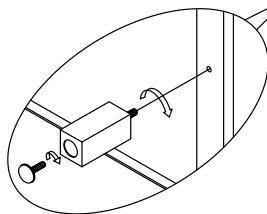
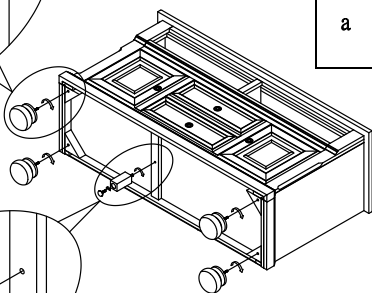
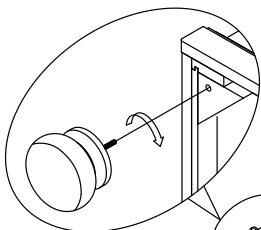

STEP 1

STEP 1: Attach bun feet (B) and support leg (C) to the bottom of TV CONSOLE (A) by turning clockwise.

**Important note:**

The furniture tipping restraint is stapled to the back of the TV CONSOLE.

The bun feet and support leg are put in a box, located inside the door.

The shelf can be removable.



AMERICAN SIGNATURE  
FURNITURE®

# ASSEMBLY INSTRUCTIONS

ITEM NO.: 2638-62B

64" TV CONSOLE-HANOVER

THANK YOU FOR PURCHASING THIS QUALITY PRODUCT. BE SURE TO CHECK ALL PACKING MATERIAL CAREFULLY FOR SMALL PARTS THAT MAY HAVE COME LOOSE INSIDE THE CARTON DURING SHIPMENT.

### TOOLS REQUIRED (NOT PROVIDED)

PHILLIPS SCREWDRIVER



### PARTS LIST:

NO	DESCRIPTION	SKETCH	QTY
A	64" TV CONSOLE		1 PC
B	BUN FEET		4 PCS
C	SUPPORT LEG		2 PC

### HARDWARE LIST:

NO	DESCRIPTION	SKETCH	SIZE	QTY
a	TIPPING RESTRAINT			1 set

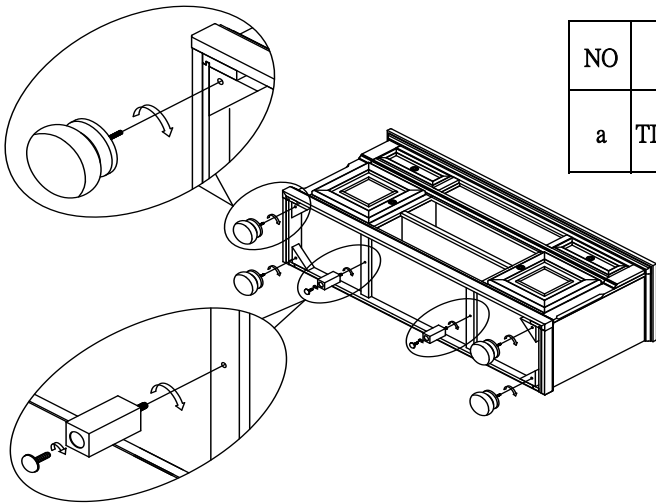
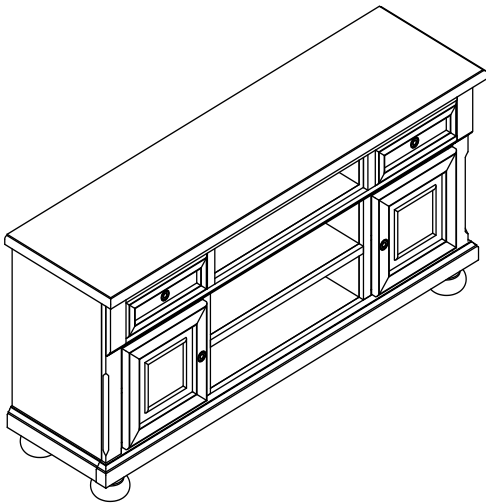

STEP 1

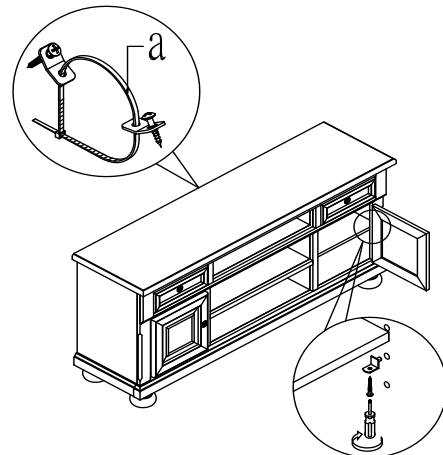

STEP 1: Attach bun feet (B) and support leg (C) to the bottom of TV CONSOLE (A) by turning clockwise.

#### Important note:

The furniture tipping restraint is stapled to the back of the TV CONSOLE.

The bun feet and support leg are put in a box, located inside the door.

The shelf can be removable.



AMERICAN SIGNATURE  
FURNITURE®

# ASSEMBLY INSTRUCTIONS

ITEM NO.: 2638-72B

74" TV CONSOLE-HANOVER

THANK YOU FOR PURCHASING THIS QUALITY PRODUCT. BE SURE TO CHECK ALL PACKING MATERIAL CAREFULLY FOR SMALL PARTS THAT MAY HAVE COME LOOSE INSIDE THE CARTON DURING SHIPMENT.

## TOOLS REQUIRED (NOT PROVIDED)

PHILLIPS SCREWDRIVER

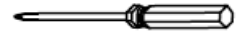

## PARTS LIST:

NO	DESCRIPTION	SKETCH	QTY
A	74" TV CONSOLE		1 PC
B	BUN FEET		4 PCS
C	SUPPORT LEG		2 PCS

## HARDWARE LIST:

NO	DESCRIPTION	SKETCH	SIZE	QTY
a	TIPPING RESTRAINT			1 set

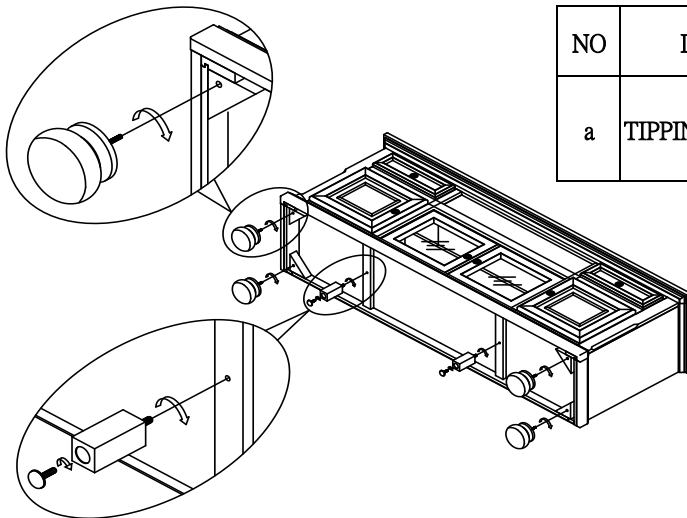
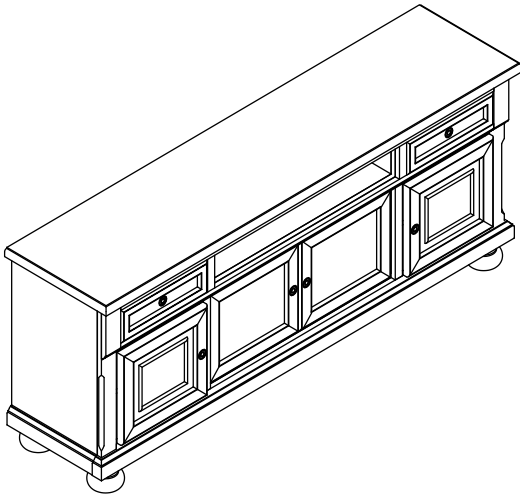

STEP 1

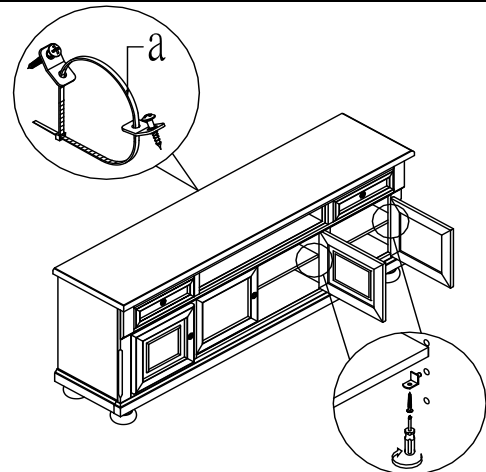

STEP 1: Attach bun feet (B) and support leg (C) to the bottom of TV CONSOLE (A) by turning clockwise.

### Important note:

The furniture tipping restraint is stapled to the back of the TV CONSOLE.

The bun feet and support leg are put in a box, located inside the door.

The shelf can be removable.



AMERICAN SIGNATURE  
FURNITURE®

# ASSEMBLY INSTRUCTIONS

ITEM NO.: 2638-02

LIFT TOP CKTL TABLE-HANOVER

THANK YOU FOR PURCHASING THIS QUALITY PRODUCT. BE SURE TO CHECK ALL PACKING MATERIAL CAREFULLY FOR SMALL PARTS THAT MAY HAVE COME LOOSE INSIDE THE CARTON DURING SHIPMENT.

**TOOLS REQUIRED (NOT PROVIDED)**

PHILLIPS SCREWDRIVER



**PARTS LIST:**

NO	DESCRIPTION	SKETCH	QTY
A	TOP		1 PC
B	DRAWER BASE		1 PC
C	LEG		4 PCS

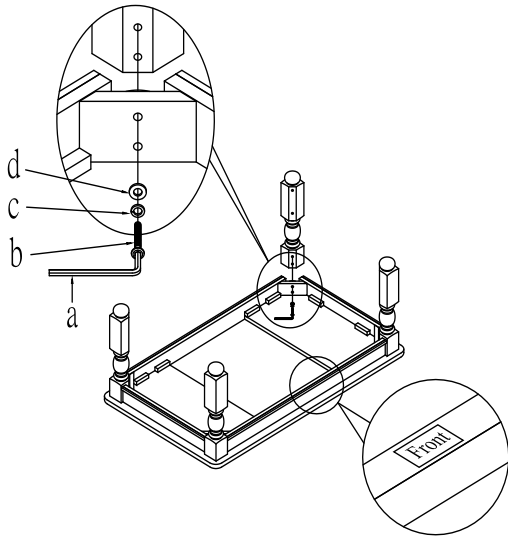

STEP 1

**HARDWARE LIST:**

NO	DESCRIPTION	SKETCH	SIZE	QTY
a	ALEEN KEY		4 x 74 x 29mm	1 pc
b	BOLT		ϕ 1/4" x 15 x 51mm	8 pcs
c	SPRING WASHER		ϕ 1/4" x ϕ 11 x 2mm T	16 pcs
d	FLAT WASHER		ϕ 1/4" x ϕ 18 x 2mm T	16 pcs
e	BOLT		ϕ 1/4" x 15 x 76mm	8 pc
f	STRAIGHT ALLEN KEY		4*100mm	1 pc

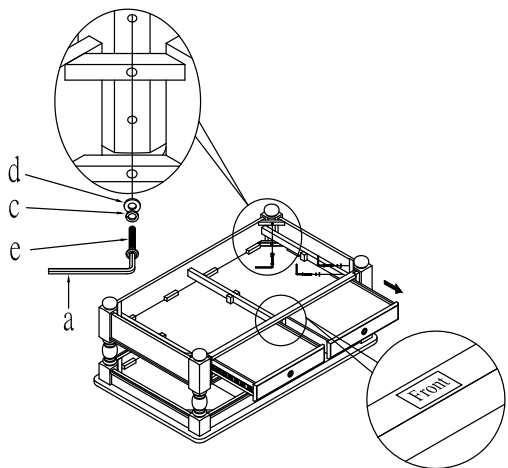

STEP 2

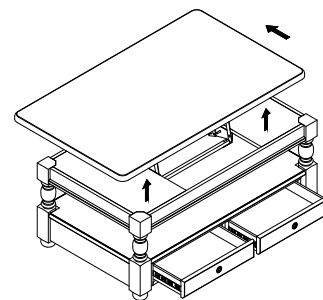
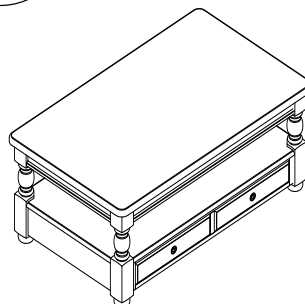

STEP 1: Attach leg (C) to the top (A) by using allen key (a), bolt (b), spring washer (c) and flat washer (d).

STEP 2: Attach drawer base (B) to the leg (c) by using allen key (a), bolt (e), spring washer (c) and flat washer (d).

# ASSEMBLY INSTRUCTIONS

ITEM NO.: 2638-05  
END TABLE-HANOVER

THANK YOU FOR PURCHASING THIS QUALITY PRODUCT. BE SURE TO CHECK ALL PACKING MATERIAL CAREFULLY FOR SMALL PARTS THAT MAY HAVE COME LOOSE INSIDE THE CARTON DURING SHIPMENT.

**TOOLS REQUIRED (NOT PROVIDED)**

PHILLIPS SCREWDRIVER





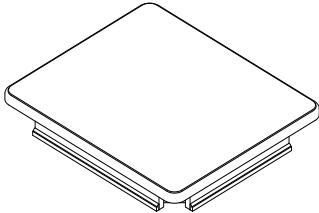
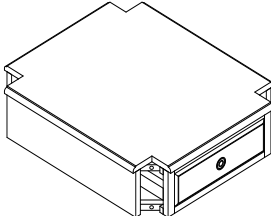
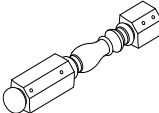

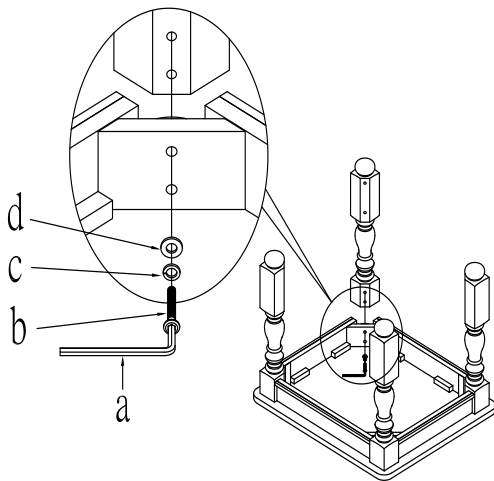

**PARTS LIST:**

NO	DESCRIPTION	SKETCH	QTY
A	TOP		1 PC
B	DRAWER BASE		1 PC
C	LEG		4 PCS



STEP 1

**HARDWARE LIST:**

NO	DESCRIPTION	SKETCH	SIZE	QTY
a	ALEEN KEY		4 x 74 x 29mm	1 pc
b	BOLT		ϕ 1/4" x 15 x 51mm	8 pcs
c	SPRING WASHER		ϕ 1/4" x ϕ 11 x 2mm T	16 pcs
d	FLAT WASHER		ϕ 1/4" x ϕ 18 x 2mm T	16 pcs
e	BOLT		ϕ 1/4" x 15 x 76mm	8 pc
f	STRAIGHT ALLEN KEY		4*100mm	1 pc

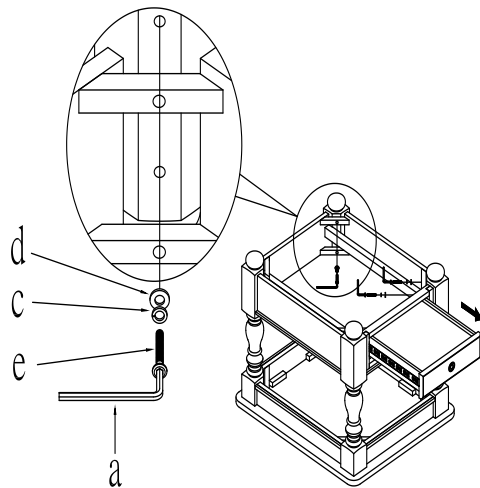

STEP 2

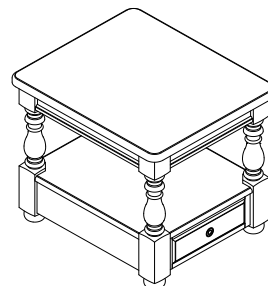

STEP 1: Attach leg (C) to the top (A) by using allen key (a), bolt (b), spring washer (c) and flat washer (d).

STEP 2: Attach drawer base (B) to the leg (c) by using allen key (a), bolt (e), spring washer (c) and flat washer (d).