



AMERICAN SIGNATURE, INC.



ASSEMBLY INSTRUCTIONS

ITEM NO: DVC100 SDC CHARLESTON WHITE
DVC200 SDC CHARLESTON GRAY
DVC300 SDC CHARLESTON TOBCC
SCROLL BACK SIDE CHAIR

Thank you for purchasing this quality product. Be sure to check all packing material carefully for small parts that may have come loose inside the carton during shipment.

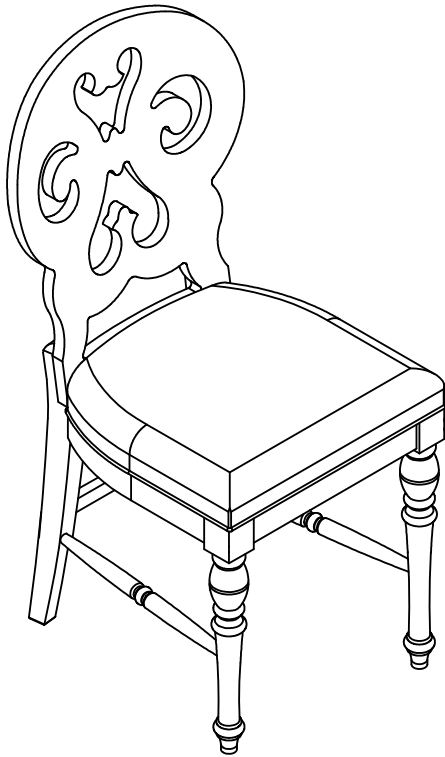

PARTS LIST:

No.	Description	Sketch	Quantity
A	Chair Back		1 pc
B	Seat		1 pc
C	Front Leg		2 pcs
D	Stretcher		2 pcs

HARDWARE LIST:

No.	Description	Sketch	Size	Quantity
E	Bolt		Ø5/16"L 44mm	7 pcs
F	Bolt		Ø5/16"L 76mm	4 pcs
G	Flat washer		Ø5/16"X19mm X2mm	11 pcs
H	Spring washer		Ø5/16"X12mm X2mm	11 pcs
I	Wood Crew		8X38mm	4 pcs
J	Allen wrench		4mm	1 pc
K	Allen wrench		4mm	1 pc

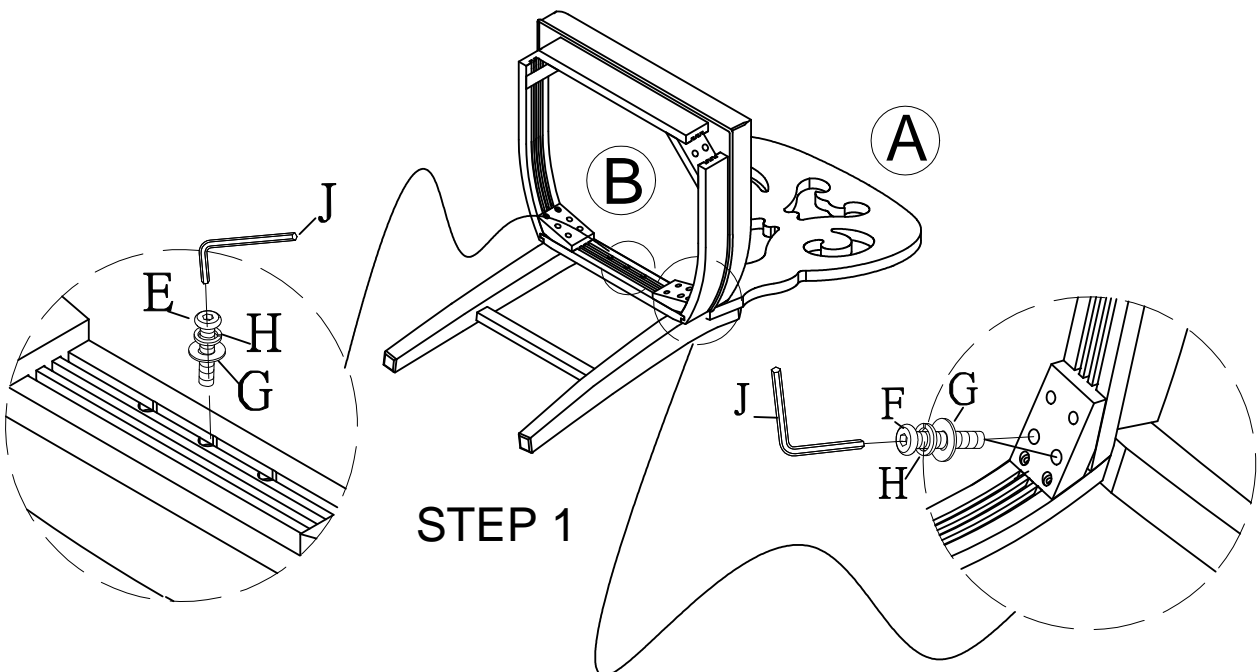

MADE IN VIETNAM



AMERICAN SIGNATURE, INC.



ASSEMBLY INSTRUCTIONS

ITEM NO: DVC100 SDC CHARLESTON WHITE
DVC200 SDC CHARLESTON GRAY
DVC300 SDC CHARLESTON TOBCC
SCROLL BACK SIDE CHAIR

Thank you for purchasing this quality product. Be sure to check all packing material carefully for small parts that may have come loose inside the carton during shipment.

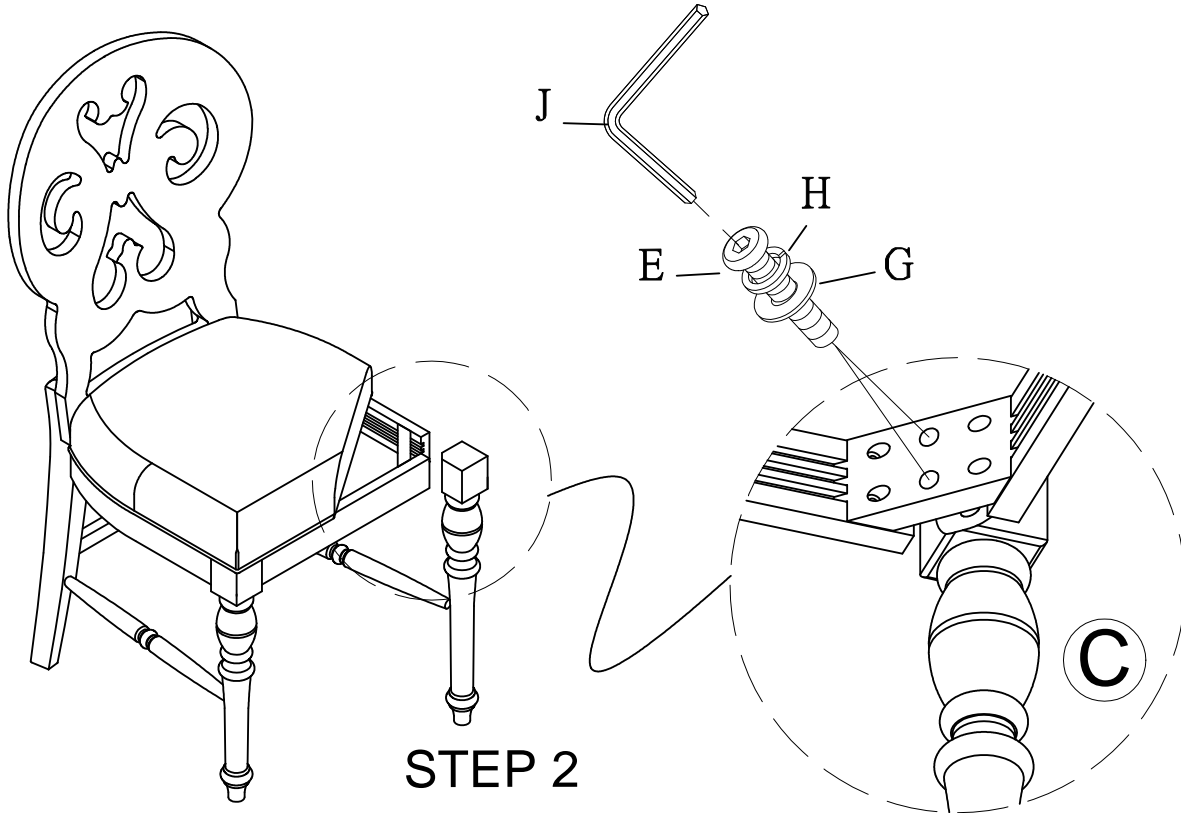

Bottom View

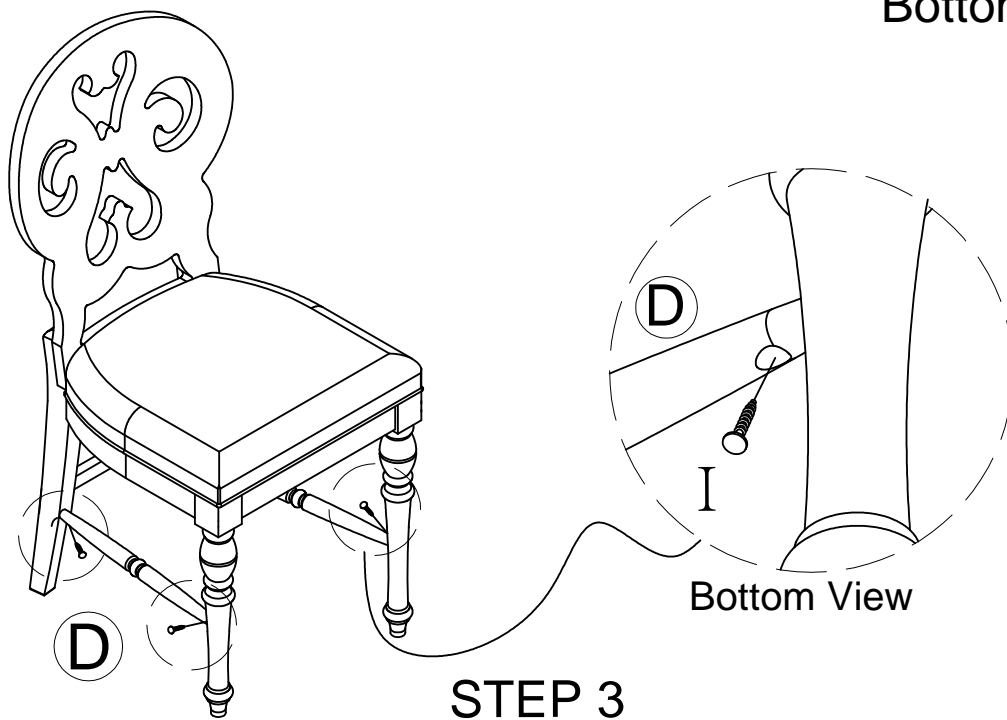

Bottom View

MADE IN VIETNAM

EXCLUSIVE AMERICAN SIGNATURE DESIGN-DO NOT REPRODUCE WITHOUT WRITTEN PERMISSION