



AMERICAN SIGNATURE, INC.



ASSEMBLY INSTRUCTIONS

ITEM NO: BVC100 5PSTH/BVC100 6PSTH CHARLESTON WHITE
BVC200 5PSTH/BVC200 6PSTH CHARLESTON GRAY
BVC300 5PSTH/BVC300 6PSTH CHARLESTON TOBCC
QUEEN POST HB / KING POST HB

Thank you for purchasing this quality product. Be sure to check all packing material carefully for small parts that may have come loose inside the carton during shipment.

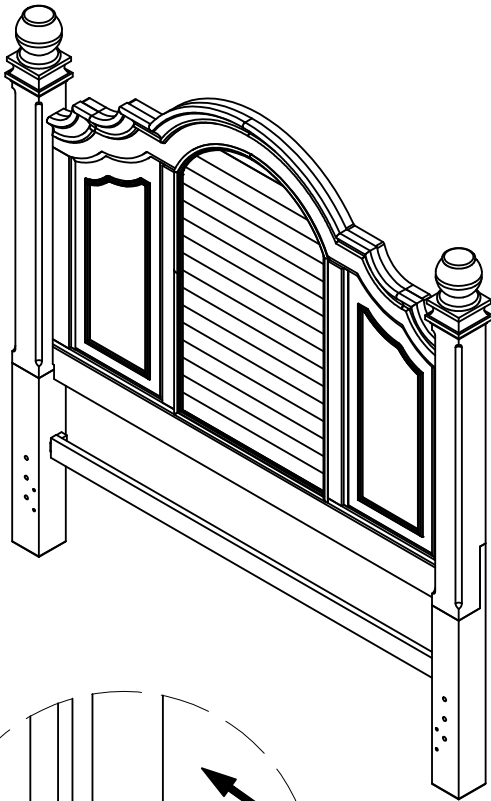

PARTS LIST:

No.	Description	Sketch	Quantity
A	Headboard Panel		1pc
B	Finial		2 pcs
C	RSF Leg		1pc
D	LFS Leg		1pc
E	Middle Rail		1pc

HARDWARE LIST:

No.	Description	Sketch	Size	Quantity
F	Bolt		Ø5/16"X18X1-3/4"	10 pcs
G	Flat washer		Ø5/16"X16mm X2mm	10 pcs
H	Spring washer		Ø5/16"X12mm X2mm	10 pcs
I	Allen wrench		4mm	1 pc
J	Allen wrench		4mm	1 pc

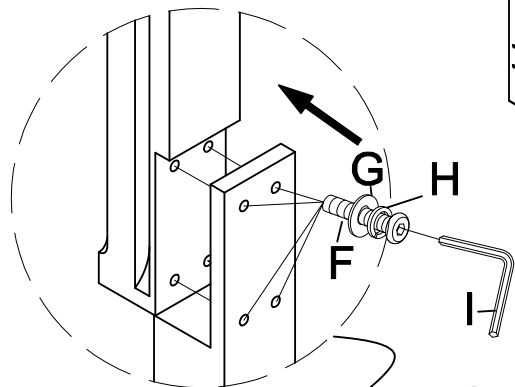

STEP 2

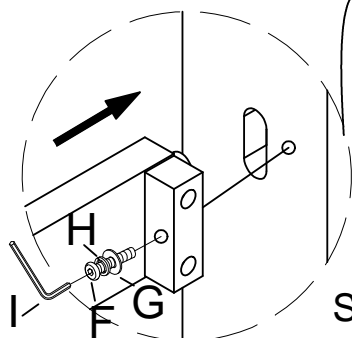

STEP 1

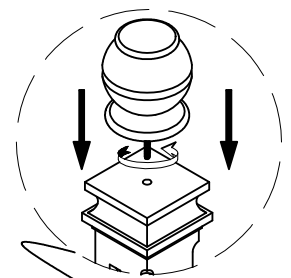

STEP 3

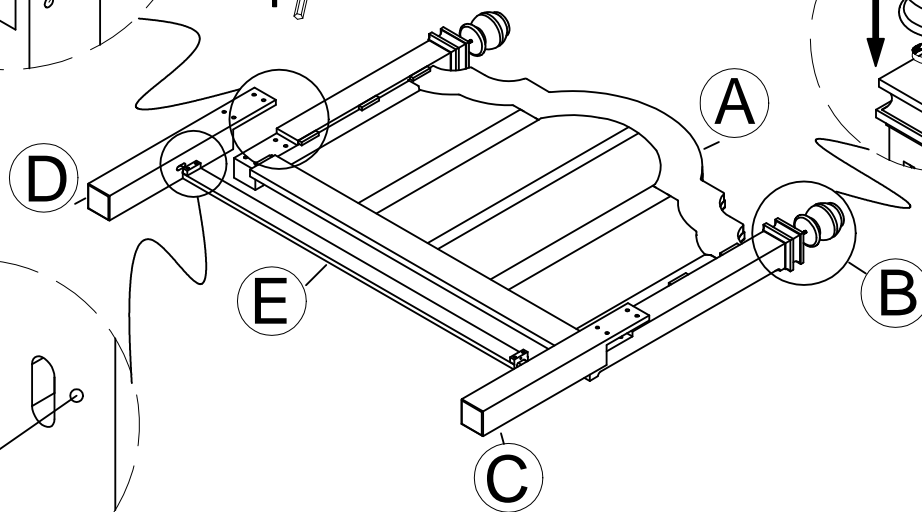

MADE IN VIETNAM

EXCLUSIVE AMERICAN SIGNATURE DESIGN-DO NOT REPRODUCE WITHOUT WRITTEN PERMISSION

ASSEMBLY INSTRUCTIONS

ITEM NO: BVC100 6PSTH/BVC100 6PSTF/BVC100 56LSSR/BVC100 56RSSR CHARLESTON WHITE
 BVC200 6PSTH/BVC200 6PSTF/BVC200 56LSSR/BVC200 56RSSR CHARLESTON GRAY
 BVC300 6PSTH/BVC300 6PSTF/BVC300 56LSSR/BVC300 56RSSR CHARLESTON TOBCC
 KING POST HB/KING POST FB W/SLT
 Q/K LEFT STRG RAIL/Q/K RIGHT STRG RAIL

AMERICAN SIGNATURE, INC.

VCF



Thank you for purchasing this quality product. Be sure to check all packing material carefully for small parts that may have come loose inside the carton during shipment.

TOOLS REQUIRED (NOT PROVIDED)

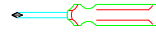

Screw Driver

PARTS LIST:

No.	Description	Sketch	Quantity
A	Headboard		1 pc
B	Footboard		1 pc
C	Left Storage Rail		1 pc
D	Right Storage Rail		1 pc
E	Roll Slats (13 slats)		1 set
F	Upper Support Leg		10 pcs
G	Lower Support Leg		10 pcs

HARDWARE LIST:

No.	Description	Sketch	Size	Quantity
H	Threaded rod		Ø5/16"X89mm	8 pcs
I	Spring Washer		Ø5/16"X12mm X2mm	8 pcs
J	Flat Washer		Ø5/16"X16mm X2mm	8 pcs
K	Hex Nut		Ø5/16"X12mm	8 pcs
L	Half moon washers		29X15X7.5mm	8 pcs
M	Wood Screw		8X25mm	26 pcs
N	Open-head Wrench			1 pcs

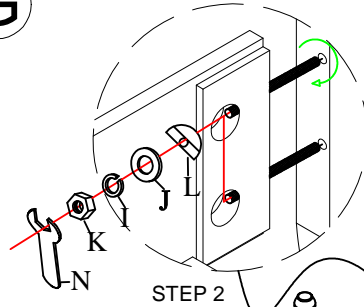
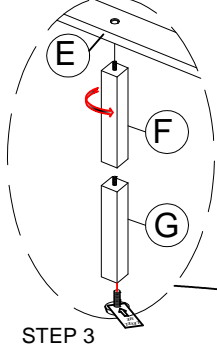
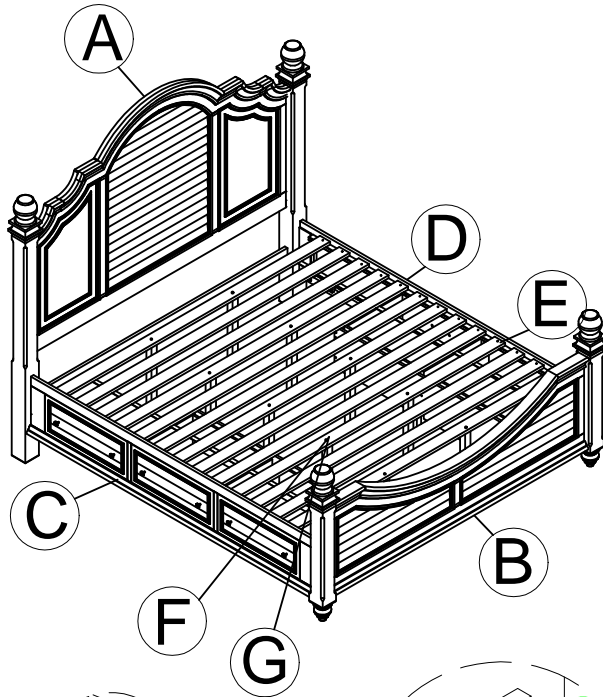

Not included

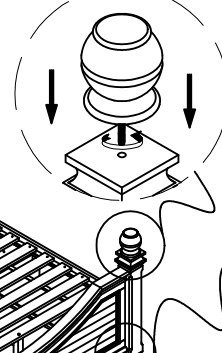
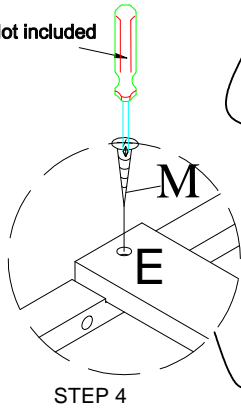

STEP 1

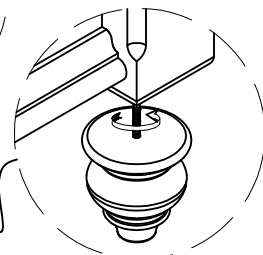

STEP 4

MADE IN VIETNAM

EXCLUSIVE AMERICAN SIGNATURE DESIGN-DO NOT REPRODUCE WITHOUT WRITTEN PERMISSION