

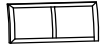



Thank you for purchasing this quality product. Be sure to check all packing material carefully for small parts that may have come loose inside the carton during shipment.





(BOX 1)
BOX OF HEADBOARD

NO	DESCRIPTION	SKETCH	QTY
A	Headboard		1
B	Headboard Leg (L/R) <small>Nail Leg</small>		2
C	Headboard Horizontal Stretcher		1







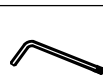

(BOX 2)
BOX OF FOOTBOARD

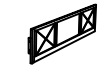
NO	DESCRIPTION	SKETCH	QTY
D	Footboard		1
E	Drawer Suppt. Rail - 2		4

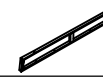

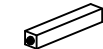





(BOX 1)
HARDWARE LIST

NO	DESCRIPTION	SKETCH	QTY
1	FLAT HEAD CHIPBOARD SCREW m4 x 32mm RBW		4
2	JCBC BOLT M6 x 35MM BLK		6
3	SPRING WASHER 1/4" RBW		6
4	FLAT WASHER 1/4" ID x 13mmOD BLK		6
5	ALLEN KEY m4 x 110mm BLK		1





(BOX 3)
BOX OF SIDERAIL

NO	DESCRIPTION	SKETCH	QTY
F	Side Rail		2
G	Bed Slat		3
H	F/Board Drawer Frame		1
I	Concealed Panel		5
J	Drawer Suppt. Rail - 1		1
K	Support Leg 1 - 30 x 30 x 518mm		5
L	Support Leg 2 - 30 x 30 x 95mm		1
M	Support Leg 3 - 30 x 30 x 107mm		1
N	Bed Slat with marking		2

(BOX 3)
HARDWARE LIST

NO	DESCRIPTION	SKETCH	QTY
6	FLAT HEAD CHIPBOARD SCREW m4 x 32mm RBW		16
7	PAN HEAD CHIPBOARD SCREW m3.5 x 20mm BLK		27
8	JCBC BOLT M6 x 35MM BLK		15
9	JCBC BOLT M6 x 50MM BLK		6
10	SPRING WASHER 1/4" RBW		15
11	FLAT WASHER 1/4" ID x 13mmOD BLK		15
12	Z-BRACKET		1
13	ALLEN KEY m4 x 110mm BLK		1

(BOX 4 & 5)
BOX OF PART & HARDWARE

NO	DESCRIPTION	SKETCH	QTY
O	Drawer - 1		2
P	Drawer - 2		1
14	HANDLE		4
15	T/HEAD M. SCREW HANDLE M4 x 48MM BLK		2
16	T/HEAD M. SCREW HANDLE M4 x 50MM BLK		2

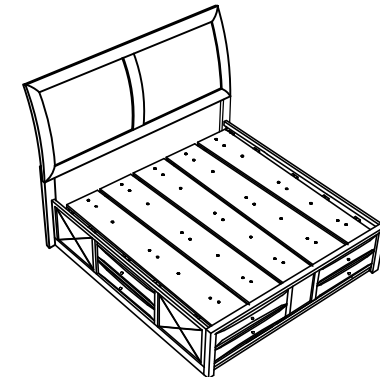

REMARK!!!

*** DRAWER 1 (O) & 2 (P) ARE IDENTICAL AND COULD BE USED IN COMMON, REGARDLESS LEFT OR RIGHT.**

NOTE : DURING ASSEMBLY, DO NOT TIGHTEN ANY HARDWARE UNTIL THE COMPLETE UNIT HAS BEEN ASSEMBLED.

MADE IN MALAYSIA

ASSEMBLY INSTRUCTIONS

STEP 4 : Attach Head Board Leg (B) to Head Board (A) as shown using JCBC BOLT (2)with Spring Washer (3), Flat washer (4) and securing with ALLEN KEY (5).

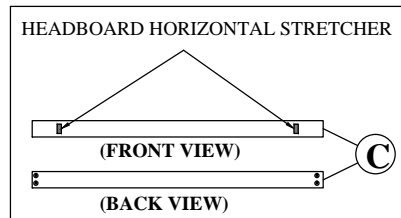
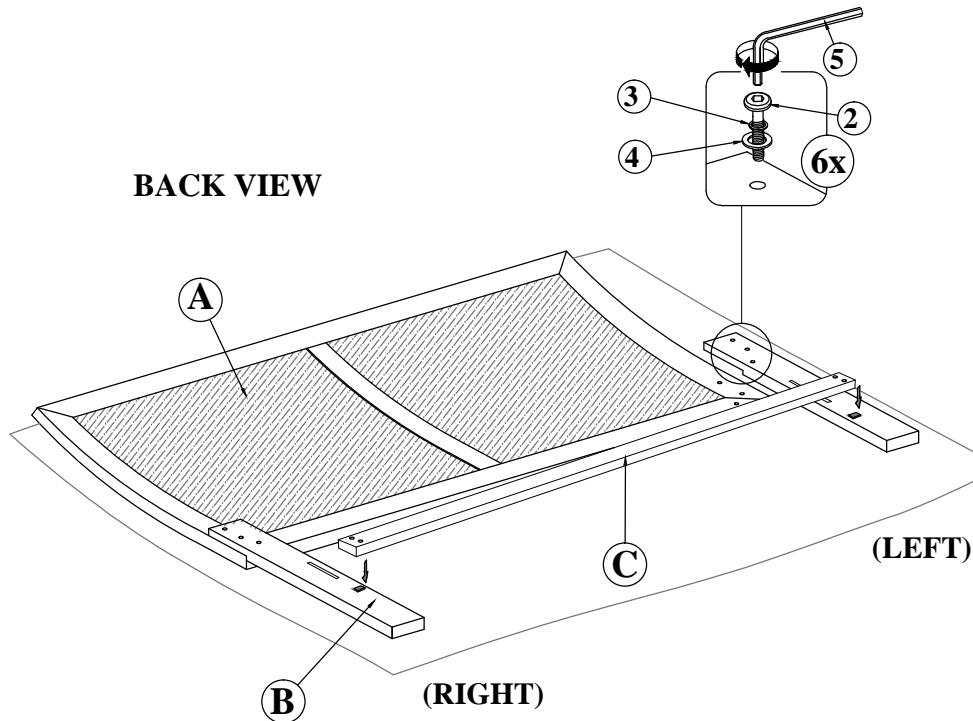

STEP 5 : Attach the Side Rail (F) to the Headboard Leg (B) and Footboard (D).Insert Spring Washer (10), Flat Washer (11),use JCBC Bolt (8) to fix with Allen Key (13).

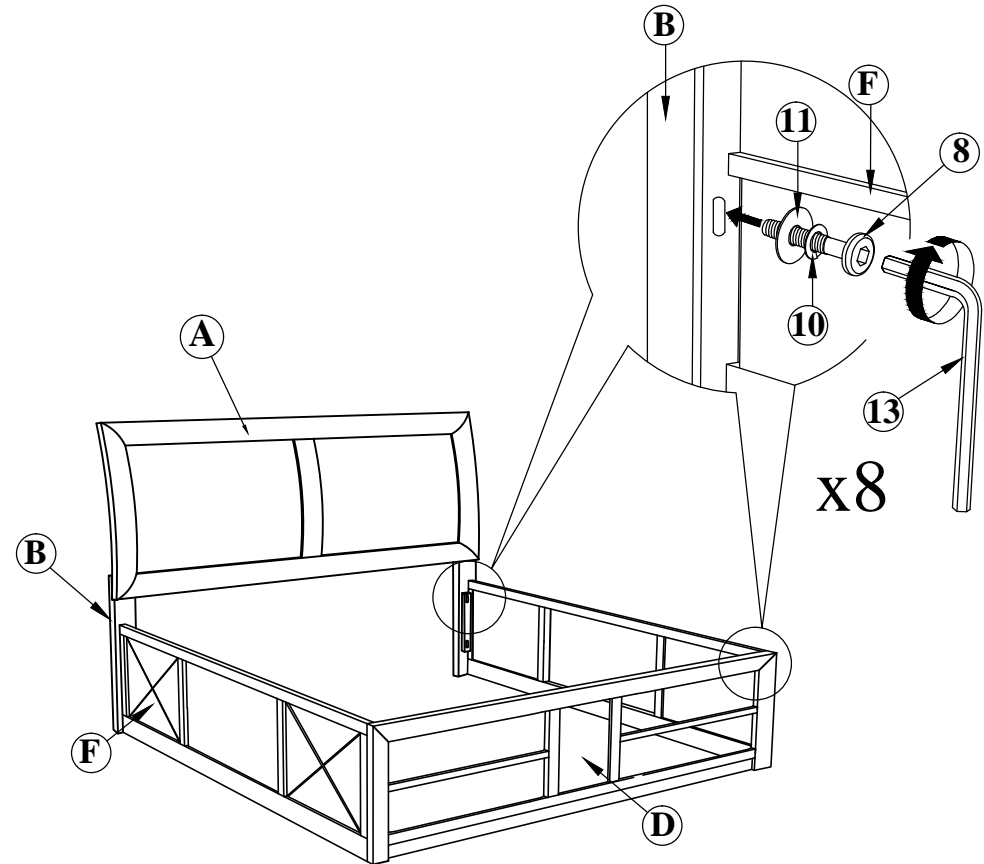

ASSEMBLY INSTRUCTIONS

STEP 6 : Attach the Footboard Drawer Frame (H) to the Side Rail (F). Insert Spring Washer (10), Flat Washer (11) & JCBC Bolt (8) to fix with Allen Key (13).

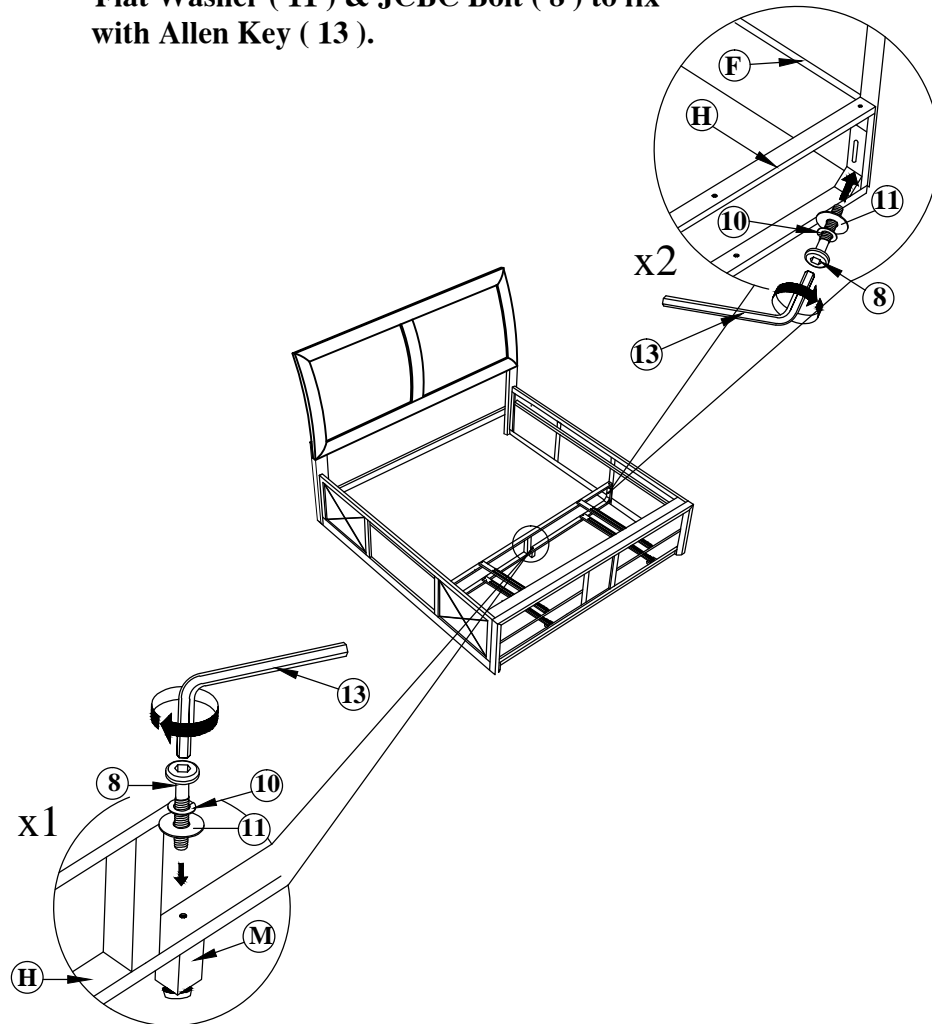

STEP 7 : Attach Support Leg 3 (M) to the Footboard Drawer Frame (H). Insert Spring Washer (10), Flat Washer (11) & JCBC Bolt (8) to fix with Allen Key (13).

STEP 8 : Attach the Drawer Support Rail (E) to the Footboard Drawer Frame (H). Insert Spring Washer (10), Flat Washer (11) & JCBC Bolt (8) to fix with Allen Key (13).

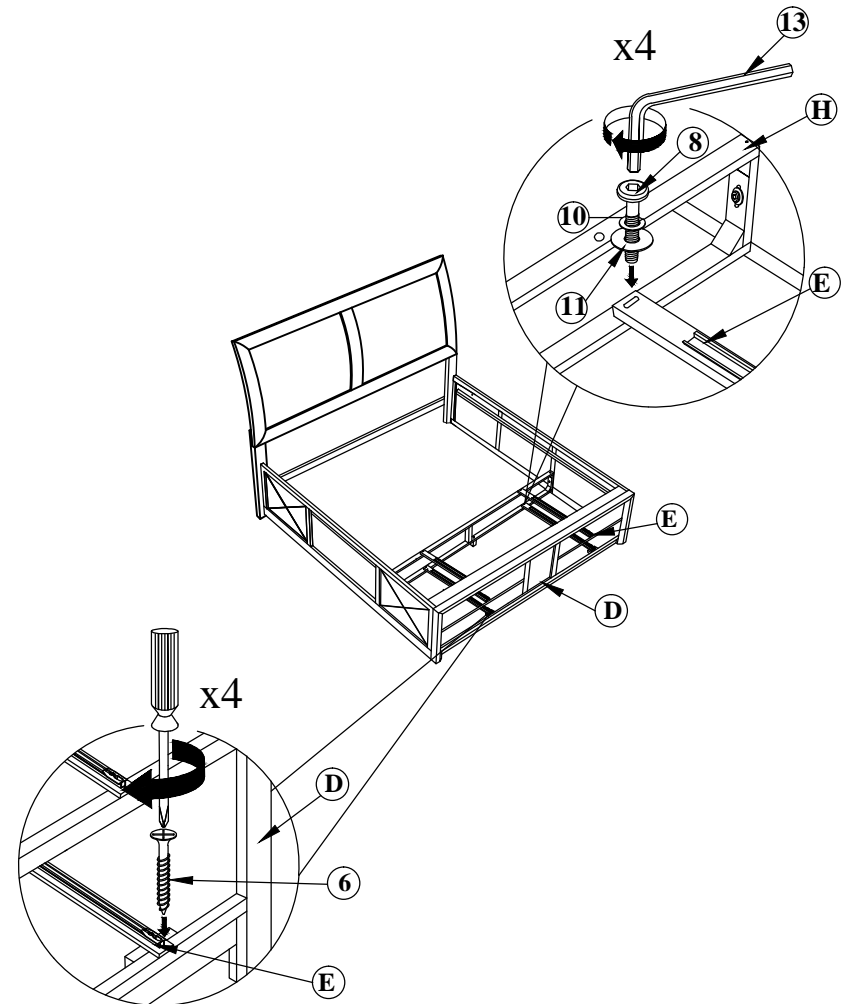

STEP 9 : Attach the Drawer Support Rail (E) to the Footboard (D) using CSK Screw (6) and tighten with Screw Driver. (Not Included)

ASSEMBLY INSTRUCTIONS

STEP 10 : Attach Support Leg 2 (L) to the Drawer Support Rail (J). Use JCBC Bolt (9) to fix with Allen Key (13).

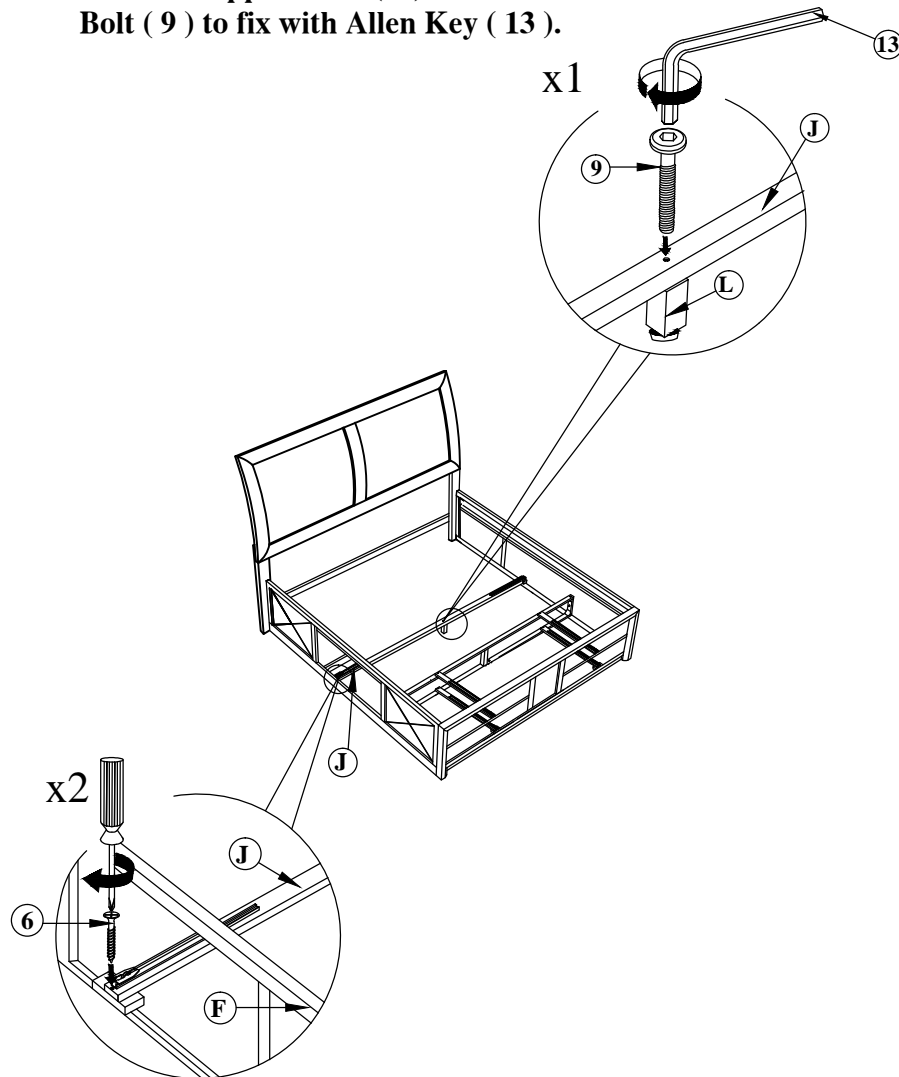

STEP 11 : Attach Drawer Support Rail (J) to the Side Rail (F) using Csk Screw (6) and tighten with Screw Driver.(Not Included)

Step 12 : Attach Bed Slat (G) & (N) to the Bed Slat Support (K). Use JCBC Bolt (9) to fix with Allen Key (13). (Loosen and tighten the Adjuster to stability of bed)

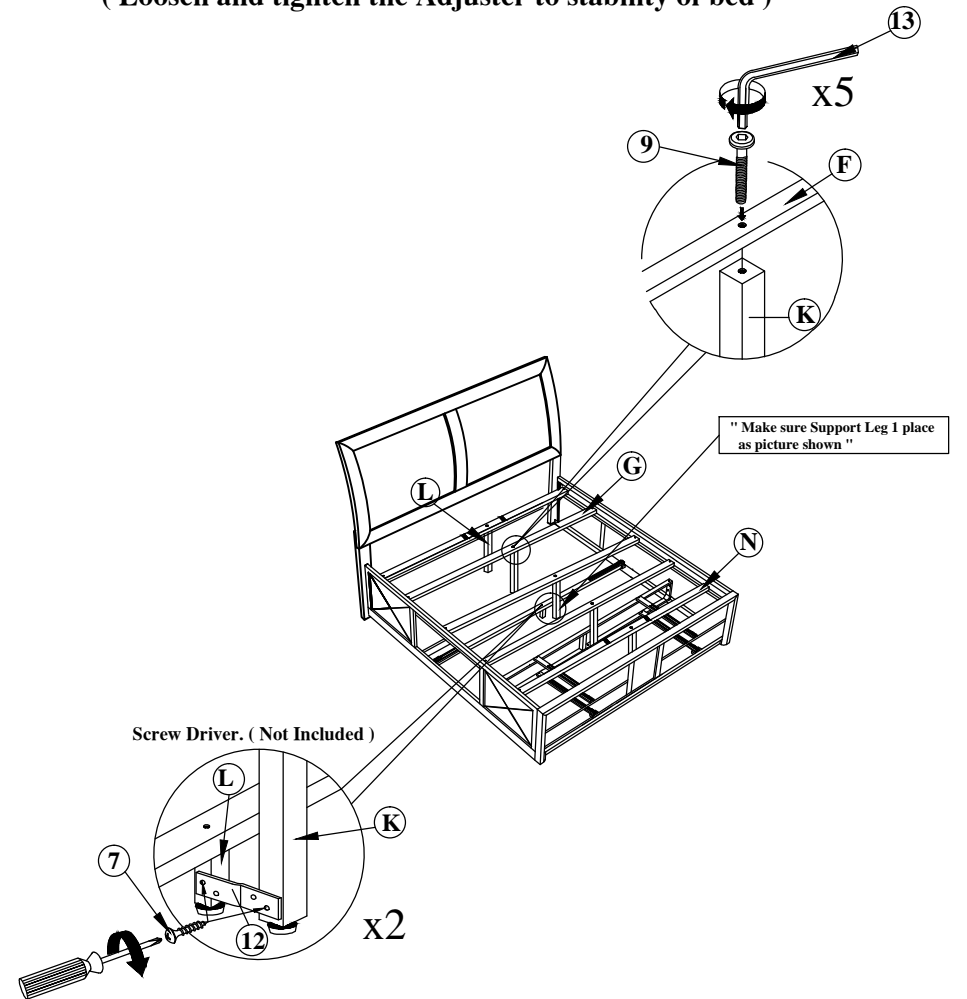

STEP 13 : Attach Z-Bracket (12) to the Bed Slat Support (K) and Support Leg 2 (L). Use Panhead Screw (7) and tighten with screw driver (not included)

ASSEMBLY INSTRUCTIONS

STEP 14 : Attach Drawer-2 (P) on Drawer Support Rail -1 (J).

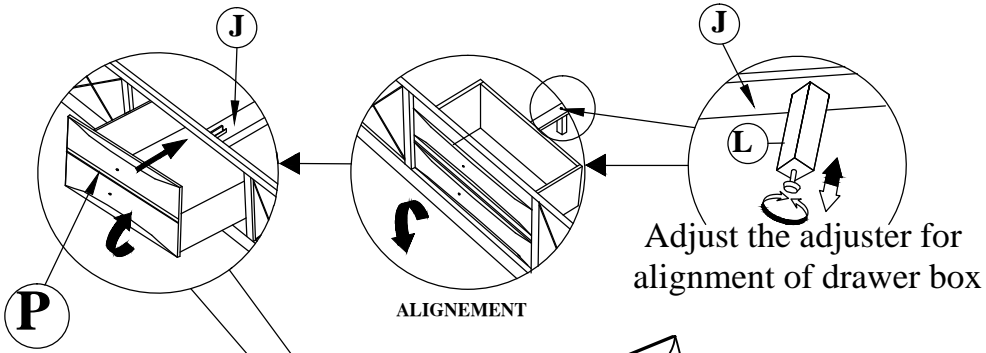

STEP 15 : Attach Drawer-1 (O) on Drawer Support Rail -2 (E).

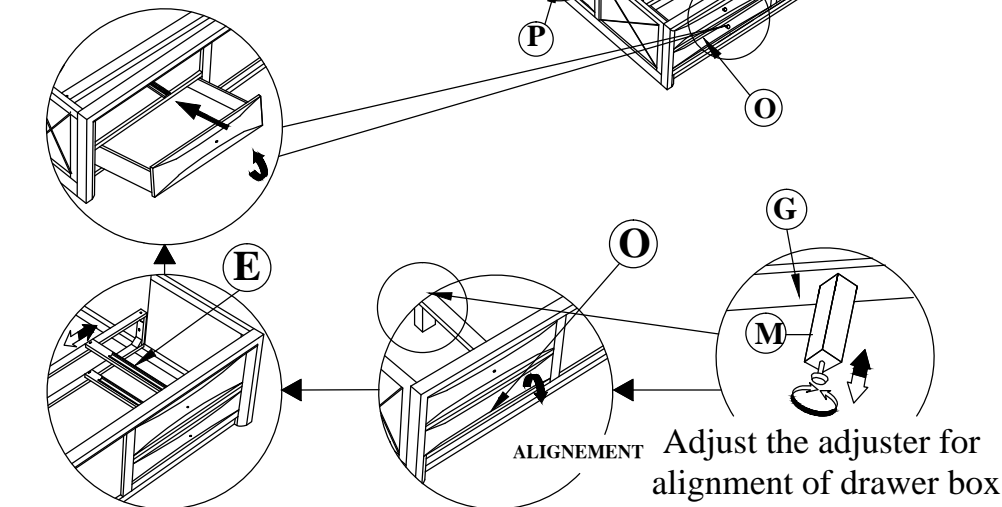

STEP 16 : Install the Handle (14) in front of drawer (P). Tighten the Handle Screw (16) using Screw Driver.(Not Included)

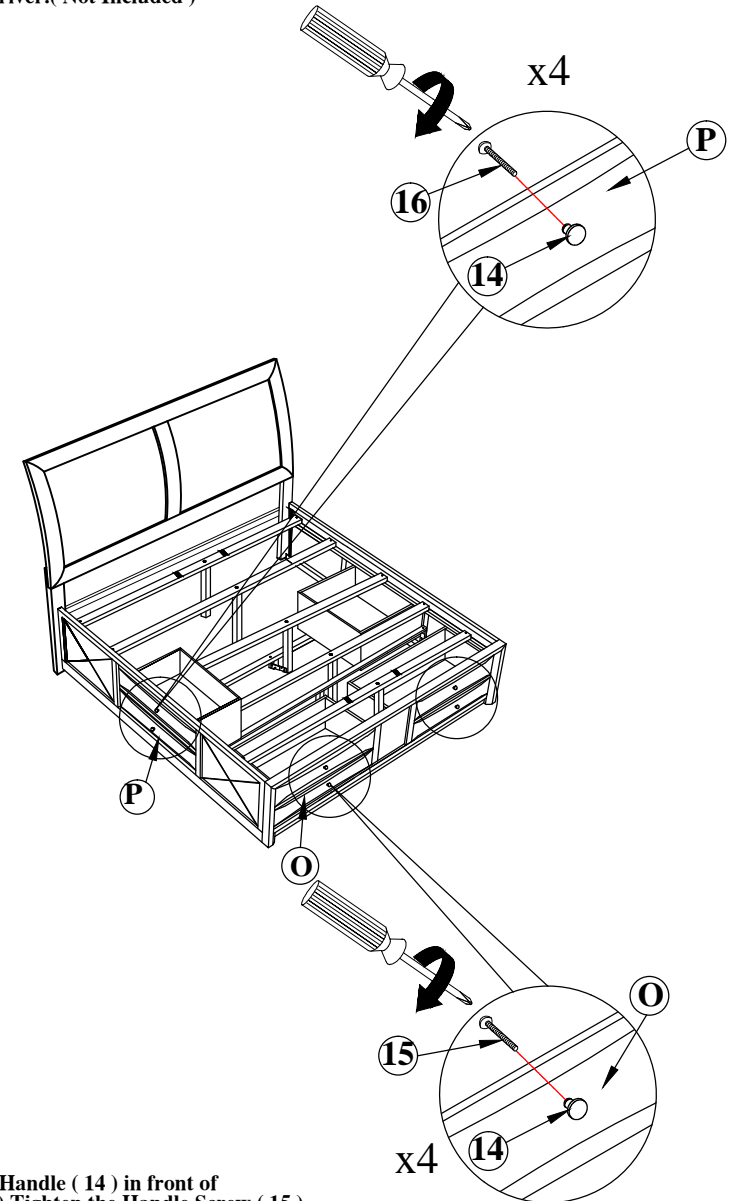

STEP 17 : Install the Handle (14) in front of drawer (O). Tighten the Handle Screw (15) using Screw Driver.(Not Included)

NOTE : MUST TIGHTEN SCREWS PERIODCALLY WITH USE SCREW WILL BECOME LOOSE CHECK TIGHTNESS OF ALL SCREW EVERY 6-8 WEEKS.

ASSEMBLY INSTRUCTIONS

STEP 18 : Push the Side Rail (F) with Bed Slat (G) and tighten with CSK Screw (6) by using Screw Driver.(Not Included) (Make sure follow the center Marking Line as shown)

STEP 20 : Attach Concealed Panel Slat (I) at the Upper Bed Slat (G) using Panhead Screw (7) and tighten with Screw Driver. (Not Included)

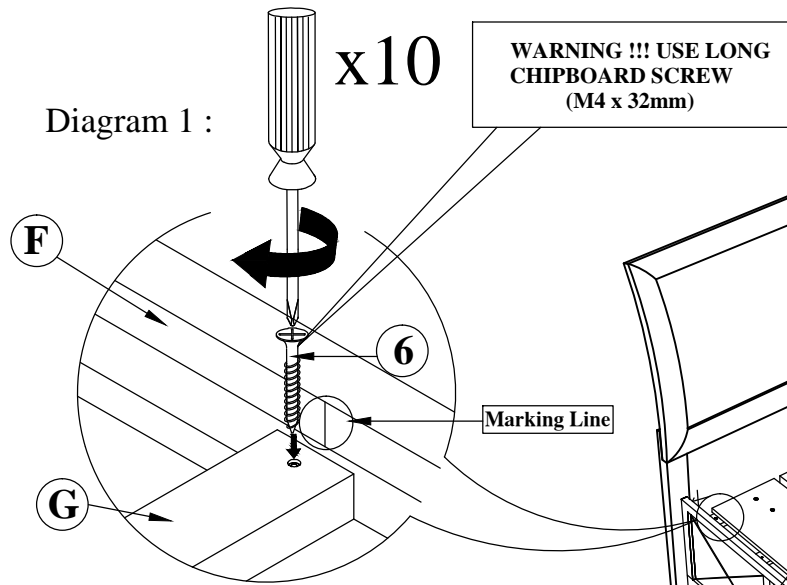

STEP 19 : Realign the Concealed Panel Slat (I) to the diagram as shown.

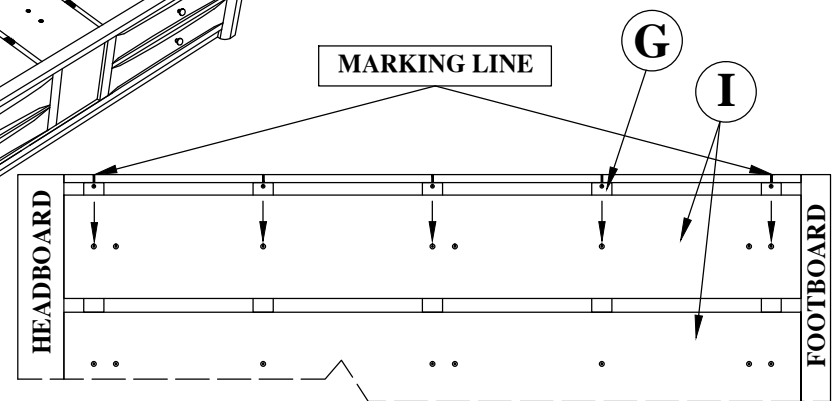
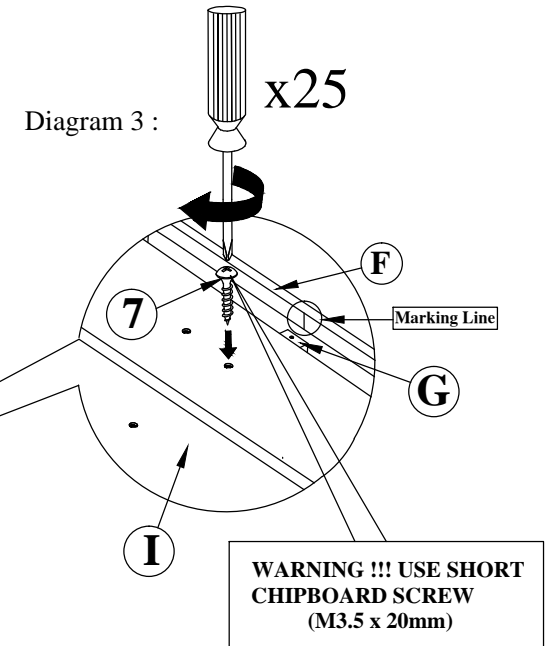
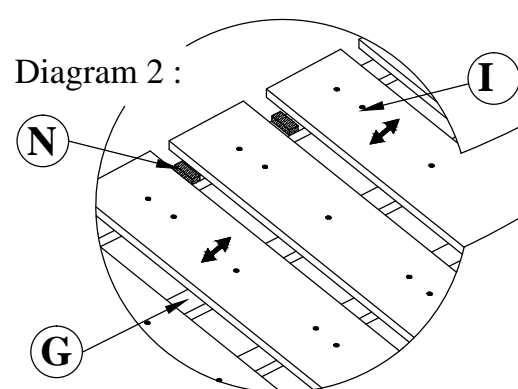

TIGHTEN THE PANHEAD SCREW (9) BY FOLLOW THE ARROW AS SHOWN

NOTE : MUST TIGHTEN SCREWS PERIODCALLY WITH USE SCREW WILL BECOME LOOSE CHECK TIGHTNESS OF ALL SCREW EVERY 6-8 WEEKS.

PAGE 6 OF 6